



Manual

Elma EVSE-200

EAN: 5706445840632









English

1 introduction

- You have acquired a high-quality test adapter manufactured, which will enable you to perform repeatable measurements for a very long period of time.
- The adapter is designed to test function and electrical safety of charging stations mode 3 for AC charging.
- This adapter allows you to conduct tests in combination with appropriate test instruments like installation Tester and /or Scope Meters [oscilloscope].
- With this adapter, charging stations can be tested in accordance with IEC/EN62851-1 and IEC/HD 60364-7-722.
- Read this manual carefully to ensure the safe performance and function of the test adapter.
- Ensure that the end user of this product receives this manual.

2 Symbols

	CAUTION Refer to the explanation in this manual.
	WARNING Hazardous Voltage, Risk electric shock.
	The equipment is protected by double insulation or reinforced insulation
	Earthing [grounding] terminal.
	Reference, please pay utmost attention.
	Conformity symbol confirms compliance with the applicable European directives. The requirements of the Low Voltage Directive with the relevant regulations Standards are also fulfilled.
	Symbol for marking of electrical and electronic equipment [WEEE Directive]

3 Safety Precautions

- This instrument must only be used by suitably trained and competent persons.
- Read this instruction manual before using the product in order to achieve maximum performance.
- Keep this manual in a safe place after reading it for future reference
- The user manual contains information and references necessary for safe operation and maintenance of the adapter.
- Please carefully read the safety information before using the test adapter.
- Failure to follow the warnings and instructions may result in electric shock, fire, serious bodily injury, or equipment damage.

3.1 Work Area Safety

- Keep your work area clean and well lit.
- Do not operate equipment in explosive atmospheres, such as in the presence of flammable liquids, gases, or dust.
Keep children and bystanders away while operating equipment.

3.2 Electrical Safety

- Do not expose equipment to rain or wet conditions.
- Water entering equipment will increase the risk of electrical shock

3.3 Personal Safety

- Stay alert. watch what you are doing and use commonsense when operating equipment.
- Do not use equipment while you are tired or under the influence of drugs, alcohol or medication.
- A moment of in attention while operating equipment may result in serious personal injury.



WARNING

- improper use of this meter can cause damage, shock, injury, or death.
- Read and understand this user manual before operating the adapter.
- If the equipment is used in a manner not specified by the manufacturer, the protection provided by the equipment may be impaired
- Use only accessories that are recommended by the manufacturer for your equipment. accessories that may be suitable for one piece of equipment may become hazardous when used with other equipment.

4 Available Measurements and Product description

- The adapter can test the electrical safety and function test of mode 3 electric vehicle charging equipment [EVSE] with type 2 connector [or optional type 1 connector].
- PE Pre-Test [potential presence of dangerous voltage at PE. terminal by mistake]-touch electrode and led lamp.
- phase indicator [presence of all three phase voltages measured to N]-three led lamps.
- PP state simulation [NC,13A,20A,32A,63A]-rotary switch.
- CP state simulation [A, B, C, O]-rotary switch.
- CP error "E" simulation [cp signal short-circuited to PE]-push button.
- PE error [earth fault] simulation [interruption of PE conductor]-push button.
- Measurements on live conductors [L1, L2, L3 and n]and an PE conductor -five 4 mm safety sockets for connection to installation testers.
- Test of cp signal-two 4mm safety sockets for connection to an oscilloscope.
- Mains socket [on frontside] to connect an external load for test purposes only.

5 Before Use

5.1 Standard Equipment

The following equipment and accessories are included in the package, before using the unit, make sure that all items are included.

- Main Unit x 1
- Type 2 Test Cable x 1
- Portable Package x 1
- Manual x 1 [This document]

5.2 Safety Measures

- The test adapter has been built and tested in compliance with the valid safety regulations and left the factory in safe and perfect condition.
- In order to maintain this condition and to ensure safe instrument operation, the user must pay attention to the references and warnings contained within this user manual.

⚠ WARNING, DANGER OF ELECTRICAL SHOCK

- In order to avoid electrical shock, valid safety and national regulations regarding excessive contact voltages must receive utmost attention when working with voltages exceeding 120V DC or 50V RMS AC.
- The respective accident prevention regulations established by the national health & safety board for electrical systems and equipment must be strictly met at all times.
- Prior to any operation, ensure that the adapter and cable assemblies are in perfect condition.
- The adapter may only be connected to charging stations as indicated in the technical specification section.
- The adapter may only be used within the operating ranges as specified in the technical specification section.
- The adapter may only be used in dry and clean environments, dirt and humidity reduce insulation resistance and may lead to electrical shocks, particularly for high voltages.
- Never use the adapter in precipitation [e.g., dew or rain]. in case of condensation due to temperature jumps, the adapter may not be used.
- Perfect tests and measurements may only be ensured within the temperature range of 0 to 40°C.
- If the operators safety is no longer guaranteed, remove the adapter from service and protect against use.
- To ensure a safe measurement only use original cable assemblies.
- If the operators safety is no longer guaranteed, remove the adapter from service and protect against use.
- Safety can no longer be guaranteed if the adapter [or cable assemblies]:

Show obvious damage.

- Do not carry out the desired tests or measurements.
- Have been stored for too long under unfavorable conditions.
- Have been subjected to mechanical stress during transport.

5.3 Appropriate Usage

⚠ ⚡ WARNING

- The adapter may only be used under conditions and for the purposes for which it was designed.
- If the adapter is modified, operational safety is no longer ensured.
- The adapter may only be opened by an authorized service technician.
- Before opening the adapter, it must be disconnected from any electrical circuitry.

6 Description of Warning Marks

1. **⚡** High danger of electric shock is present when PE Pre-Test indicator lights while performing PE Pre-test, in this case, further testing must be stopped immediately, ensure a sufficiently connection of your body to earth while performing this test.

2. **⚠** Terminals with low voltage output [Approx. ±12V] powered by the charging station, terminal marked with $\frac{\perp}{\equiv}$ is connected to PE, use for test purposes only, in the case of wrong wiring or error of the charging station, these terminals may present a hazard.

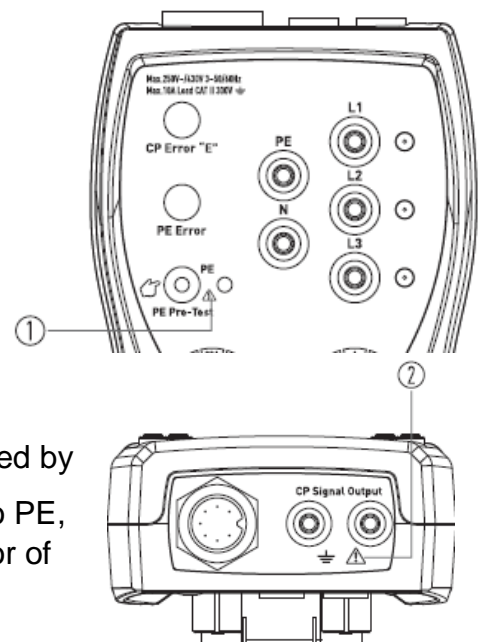

7 Operation Elements and Connectors

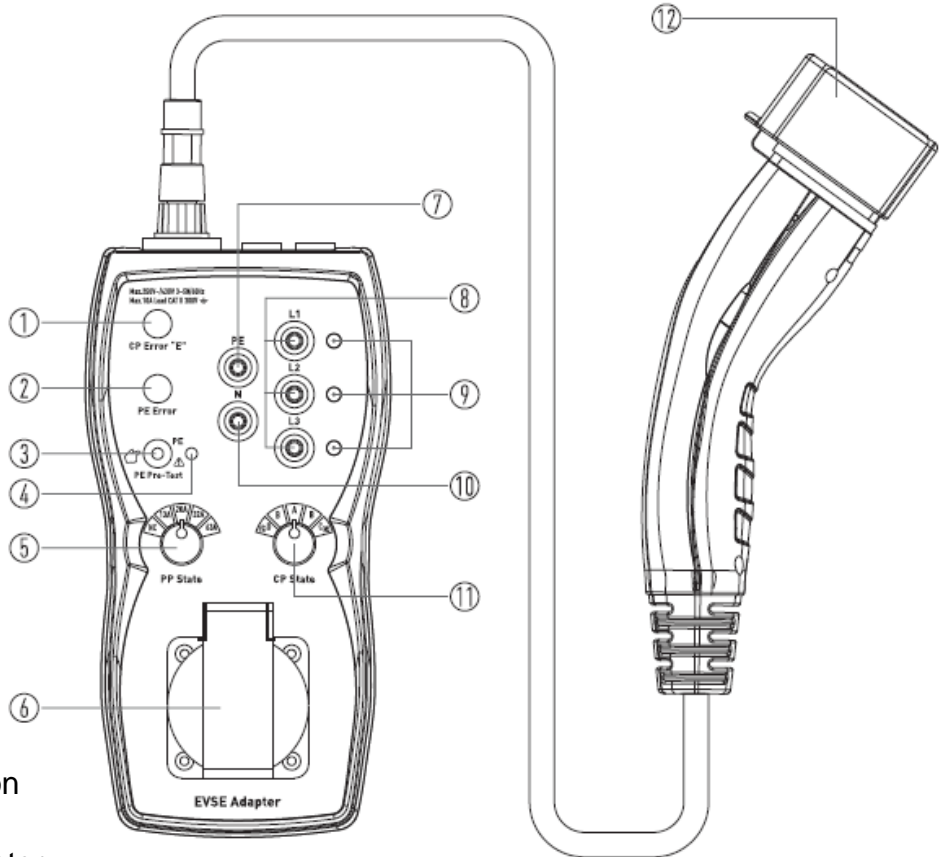

- 1. CP Error “E” Button
- 2. PE Error [Earth Fault] Button
- 3. PE Pre-Test Touch Probe
- 4. PE Pre-Test Warning indicator
- 5. PP [Proximity Pilot] State Rotary Switch Selector [NC,13A,20A,32A and 63A]
- 6. Mains socket, use for test purpose only, Max allowed current=10A.
- 7. Measuring Terminal PE
- 8. Measuring Terminal L1, L2, L3
- 9. Phase indicators of L1, L2, L3 Terminals
- 10. Measuring Terminal N
- 11. CP [Control Pilot] State Rotary Switch Selector [A, B, C, D]
- 12. Fixed test cable for EV charging station Type 2

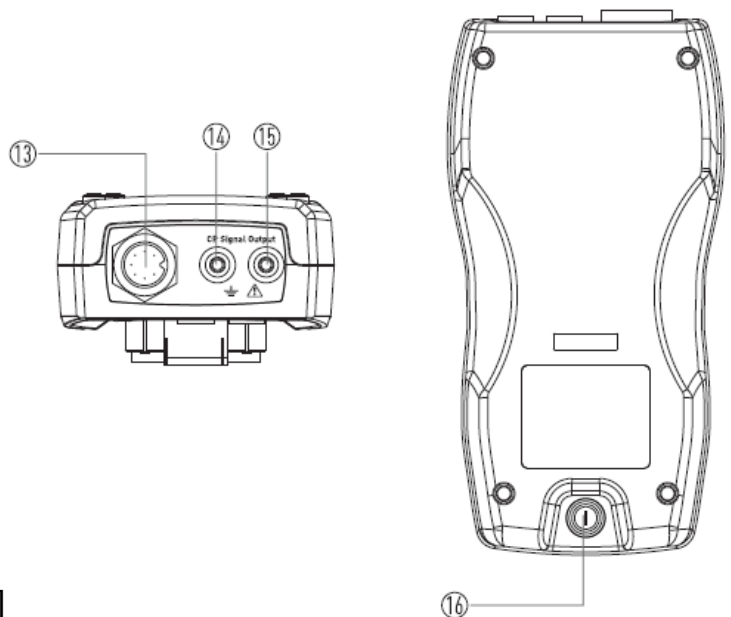

- 13. Test Cable Input
- 14. CP Signal Output Terminal
- 15. CP Signal Output Terminal [Conn. to PE]
- 16. Fuse 10A/250V. 5x20mm Protects Mains Socket Against Overload

8 Testing Charging Stations

8.1 Purpose of the Test adapter

There are two main purposes of the Test adapter:

1. To simulate connection of an electrical vehicle to the tested charging station [the test adapter simulates electrical vehicle and charging cable] connection of the test adapter to a charging station triggers the charging process in the charging station [CP switch at the adapter shall be in appropriate model. various cable charging capabilities can be simulated [NC,13A,20A,32A and 63A] as well as all possible electrical vehicle modes [A, B, C D].
2. To provide easy access to charging terminals L1, L2, L3, N, PE and to CP signal terminals to which additional measuring equipment can be connected for further testing, charging stations should be tested after installation and repeated periodically.

Please refer to the manufacturers recommendation and national standards which are linked to IEC/HO 60364-6 for initial test or IEC/HO 60364-7-722, required tests are:

- Visual inspection
- Continuity of protective conductors and protective bonding.
- Insulation resistances - Loop/Line impedance and RCO test
- Function tests [including but not limited to]:
 - Vehicle state A, B, C, D
 - Error handling [error "E", PE Error [Earth Fault...]]
 - Communication [PWM signal]
 - Mechanical locking of plug
 - Rotary field/phase sequence
 - Other tests

8.2 Connection of the Test adapter to charging station

The Test Adapter can accept the following two connection cables:

- TYPE 2 test cable; for charging stations type 2 with panel mount with socket outlet or fixed cable with vehicle connector [included in scope of supply].
- TYPE 1 test cable; for charging stations type 1 with fixed cable and vehicle connector [Options].

Connect the test adapter to the charging station:

- Connect to the charging station to be tested as shown in this Figure.
-

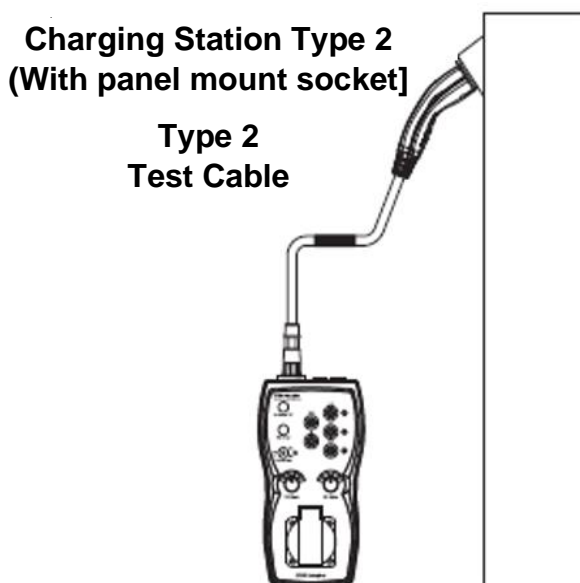

Connection of the test adapter to a charging station type 2 with panel mount socket outlet

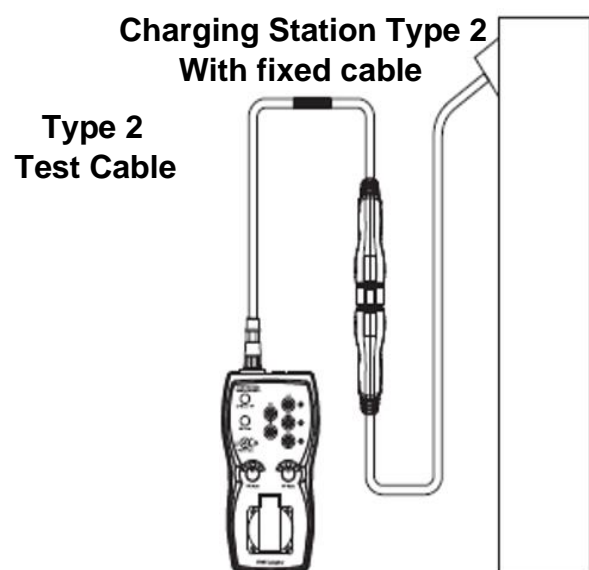

Connection of the test adapter to a charging station type 2 with fixed cable and vehicle connector

8.3 Operation of a charging station to be tested

8.3.1 PE Pre-test

- Do not touch the PE terminal on the front power socket until the PE pretest is successful.
- The **PE Pre-Test** is a safety feature of the test adapter, it allows the operator to test the PE conductor for possible presence of dangerous voltage against earth.
- In normal circumstances, the PE conductor is connected to earth and therefore has no voltage against earth however if the PE conductor is not connected to earth [e.g., connected to phase by mistake or PE is interrupted] the situation may be hazardous.
- Test procedure:
 - 1-First connect the adapter firmly to the charging station.
 - 2-Then touch the probe with a bare finger.
- If light indicator is illuminated, then dangerous voltage is present at PE conductor, stop further testing immediately and check for a possible wiring fault of the tested PE conductor
-  In case of this error, PE terminal carries hazardous voltage, there is a high risk of electric shock to the operator and other persons nearby!
- Possible errors are, PE interrupted/not connected/PE carries voltage [e.g., connected to phase].
- Do not wear gloves while performing this test and ensure a proper connection to earth.
- In case of improper connection to earth [e.g., isolated placement of your body] this indication may be not reliable.

**Charging Station Type 2
(With panel mount socket)**

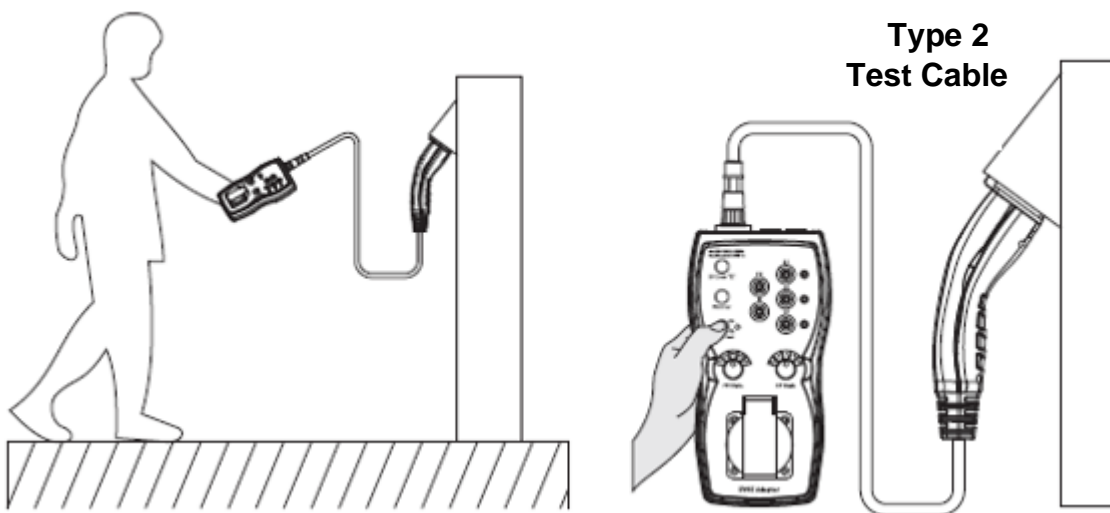

8.3.2 Proximity Pilot (PP) State (Cable Simulation)

- With the PP State rotary switch various current capabilities of the charging cable can be simulated when the test adapter is connected to the charging station.
- Current capabilities are simulated with different resistances connected between PP and PE conductors. Correlation between resistance and current capability of the charging cable is shown in Table below:

Correlation between resistance and current capability of the charging cable	
Marking of cable current capability	Resistance between PP and PE
No cable	Open (∞)
13A	1.5k Ω
20A	680 Ω
32A	220 Ω
64A	100 Ω

8.3.3 Control Pilot (CP) State (Vehicle Simulation)

- With the CP State rotary switch selector various vehicle states can be simulated when the test adapter is connected to the charging station.
- Vehicle states are simulated with different resistances connected between CP and PE conductors.
- Correlation between resistance and vehicle is shown in Table below:

Correlation between resistance and current capability of the charging cable			
Marking of Vehicle State	Vehicle State	Resistance between CP and PE	Voltage at CP terminal 1kHz)
A	Electric vehicle [EV] not connected	Open (∞)	$\pm 12V$
B	Electric vehicle [EV] connected, not ready to charge	2.74k Ω	+9V/-12V
C	Electric vehicle [EV] connected, ventilation not required, ready to charge	882 Ω	+6V/-12V
D	Electric vehicle [EV] connected, ventilation required, ready to charge	246 Ω	+3V/-12V

8.3.4 CP Signal Output Terminals

- CP output terminals are connected to CP and PE conductors of the tested charging station via the test cable, the green socket is connected to PE.
- This output is intended for connection of an oscilloscope to check the waveform and amplitude of the CP signal. Control Pilot function uses Pulse Width Modulation [PWM].
- The purpose of the Control Pilot function is communication between a vehicle and charging station, the duty cycle of the PWM signal defines the possible available charging current.
- For details of communication protocol please refer to IEC/EN 62851-1& IEC/HD 60364-7-722 and the documentation of the manufacturer of the charging station.

8.3.5 CP Error "E" Simulation

- With the CP Error "E" button CP Error can be simulated (acc.to standard IEC/EN 6185-1).
- When CP error "E" is pushed, a short circuit between CP and PE through internal diode is made.
- As a result, the pending charging process is aborted.

8.3.6 PE Error (Earth Fault) Simulation

- With the PE Error button an interruption of the PE conductor is simulated.
- As a result, the pending charging process is aborted.

8.3.7 Phase indicator

- The phase indicator consists of three LED lamps, one for each phase.
- When the test adapter is connected to the charging station and phase voltages are present at the charging connector, the LED indicators will illuminate.

Notes:

- In the case neutral[N] conductor is not present, or it is interrupted, LED indicators will not indicate possible voltage presence at L1, L2 and L3 conductors.
- The LED indicators cannot be used for phase sequence testing.
- If the charging station has only a single-phase output only one LED will illuminate.

8.3.8 Mains Socket

- The mains socket is connected to L1, N and PE conductors of the charging station via the test adapter when it is connected to the charging station.
- This output is intended for measuring purposes only and offers the possibility to check if the electric power meter works and counts in the right manner [load test].
- Therefore, an external load can be connected for measuring purposes only, it is not allowed to supply anything else.
- The max current is limited to 10A, the mains socket is protected against overload with 10A/250V,5x20mm fuse.

8.3.9 Measuring Terminals L1, L2, L3, N and PE

- Measuring terminals are directly connected to L1, L2, L3, N and PE conductors of the tested charging station via the test cable.
- These terminals may be used for measuring purposes only, it is not allowed to draw current over a longer period or supply anything else.
- An appropriate measurement instrument is needed.

9 Maintenance

- When using the test adapter in compliance with the user manual. no special maintenance is required.
- However, should functional errors occur during normal operation, the after sales service will repair your instrument.
- Please contact the local service office.

9.1 Cleaning

- If the adapter needs to be cleaned after usage, use a wet cloth and a mild household detergent.
- Prior to cleaning, disconnect the test adapter from all measurement circuits.
- Never use acid-based detergents or dissolvent liquids for cleaning.
- After cleaning, do not use the test adapter until it is dried completely.

9.2 Transport and Storage

- Please keep the original packaging for future transport [e.g., if calibration is necessary). any transport damage due to faulty packaging will be excluded from warranty claims.
- The adapter must be stored in dry, closed areas.
- In case of an adapter being transported in extreme temperatures, a minimum recovery time of 2 hours is required prior to any operation.

9.3 Fuse Replacement

- The fuse [10A [H]/250V. 5x20mm] may be blown if no voltage is present between the Land N terminals of mains socket when the charging connector is connected to the charging station and the charging station is in charging mode.
- If a fuse blow (due to overload or improper operation), follow these steps below for replacement:
 4. Unscrew the fuse holder cap using an appropriate screwdriver.
 5. Remove the defective fuse and replace it with a new one.
 6. Replace the fuse holder cap.



If the fuse blows several times the adapter must be sent to Elma Instruments in order to be checked.



Use only fuses as defined in technical specification, using alternative fuses may create a safety risk!

10 Specifications

Functions

PE Pre-Test	Yes
PP Simulation	NC/13A/20A/32A/63A
CP States	A [Electric vehicle not connected] B [Electric vehicle connected, not ready to charge] C [Electric vehicle connected, ventilation not required, ready to charge] D [Electric vehicle connected, ventilation required, ready to charge]
CP Error "E"	On/Off
PE Error [Earth Fault]	On/Off

Outputs (for test purpose only)

Measuring Terminals L1, L2, L3, N and PE	Max. 250/430V.CAT II 250V, max.10A.
Mains Socket	Max.250V, CAT II 250V, allowed current max.10A. Note: Do not load mains socket simultaneously with measuring terminals! Fuse 10A/250V,5x20mm, Magnetic tube produced by Xunlibang
Mains Socket Protection	Approx. ±12V, CAT 0 (Under normal condition) In case of wrong wiring or error of the charging station these terminals may become hazard =>up to max. CAT II 250V against PE.
CP Signal Output Terminals	

General Features

Input Voltage	Up to 250V [Single phase system]/up to 430V [Three phase system]. 50/60Hz, max 10A.
Type 2 Test Cable	AC charging mode 3, suitable to IEC62196-2 type 2 socket outlet or fixed cable with vehicle connector [Type 2, 7P three-phase]. Approx.1kg Adapter size: 227x109x63mm [Length without connection test cable] Handle size: 250x115x61 mm [Length without connection cable]
Weight	IEC/EN 62851-1/IEC/HD 60364-7-722
Dimensions [L x W x H]	250V CATII IP44 2 II 0 to 40°C -10 to 50°C 10 to 60% relative humidity w/o condensation 10 to 85% relative humidity w/o condensation Max. 2000m
Safety	
Measurement Category	
IP-Rating	
Pollution Degree	
Protection Class	
Working Temperature Range	
Storage Temperature Range	
Reference Humidity Range	
Working Humidity Range	
Altitude Above Sea Level	



Elma Instruments A/S
Ryttermarken 2
DK-3520 Farum
T: +45 7022 1000
F: +45 7022 1001
info@elma.dk
www.elma.dk

Elma Instruments AS
Garver Ytteborgsvei 83
N-0977 Oslo
T: +47 22 10 42 70
F: +47 22 21 62 00
firma@elma-instruments.no
www.elma-instruments.no

Elma Instruments AB
Pepparvägen 27
S-123 56 Farsta
T: +46 (0)8-447 57 70
F: +46 (0)8-447 57 79
info@elma-instruments.se
www.elma-instruments.se