



Elma DT 178A

DK: 63 98 206 730

SE: 42 001 25

NO: 80 626 77

EAN: 5706445840335



English usermanual

Safety information

Read the following safety information carefully before attempting to operate or service the meter.

Use the meter only as specified in this manual :

- Environment conditions
 - ① Altitude lower than 2000 meters
 - ② Relatively humidity $\leq 90\%RH$
 - ③ Operation Ambient $0 \sim 40^{\circ}C$
- Maintenance & Clearing
 - ① Repair or servicing not covered in this manual should be performed by qualified personnel.
 - ② Periodically wipe the case with a dry cloth. Do not use solvents or eradicator on this instrument.
- Safety symbols 
Comply with EMC 

Function description

This datalogger is engineered to record acceleration data of shock/vibration. This device will record and time 3-axis vibrations and peaks to provide a history of shock/vibration conditions. It is applied to the shock/vibration measurement such as transportation and Shipping Applications, building vibration, endurance testing , etc.

- Records 3-axis shock/vibration
- Build-in accelerometers
- Measures dynamic and static acceleration
- Real-time operation
- Normal & Motion detection mode
- Real-time FFT for frequency analyse
- Manual & Automatic start

Note:

In motion detection mode, the datalogger only takes data after the trigger level(user preset) is exceeded.

Specification

Acceleration Sensor: MEMS Semiconductor

Acceleration Range: $\pm 18g$

Acceleration Resolution: 0.00625g

Calibrated Accuracy: $\pm 0.5g$

Frequency Range: 0Hz ~ 60Hz

Data Memory: 4Mbit FLASH (85764 peak acceleration samples)

Data Format: time stamped peak acceleration and freefall, average and peak vector sum

Sampling Rate: 1 second to 24 hours

Power: 3.6V battery, specs:14250 or 1/2AAA

Power Consumption: 1mA (average) recording, <15µA idle

Battery Life: About 1000 hours

Computer Interface: USB

Operation temperature and humidity: 0°C ~40°C, 10%RH~90%RH

Storage temperature and humidity: -10°C ~+60°C, 10%RH~75%RH

Dimension:

The pedestal: 106mm x 56mm x 33.5mm

The datalogger: 95mm x 28mm x 21mm

System Requirement: Windows 2000 or Windows XP or Vista

Minimum hardware requirement : 8M EMS memory,2M hard disk,a free USB jack

Accessories: instruction manual, battery, windscreen, transparent cap, CD, USB cable, pedestal.

Name of parts and positions

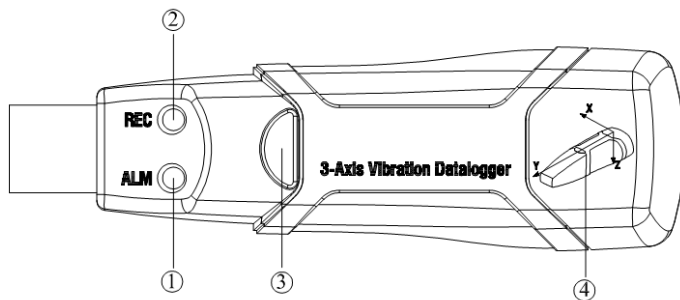

- Red Green LED
- Green Red LED
- Button: turn on/off the Datalogger
- Direction indication of 3-axis

Led flash indication

LEDs	Meaning	Action
ALM REG ● ●	No LEDs flash -No logging started -No battery fitted -Battery completely discharged	Fit Battery Data won't lose. Replace battery and download data
ALM REG ● ●	Green single flash every 10 sec. * --Logging	Press the black button in housing of datalogger untill Green LED flash four times sequencely, and then logging will start
ALM REG ● ●	Red single flash every 30 sec.* --Low battery	If logging , it will stop automatically.Data won't los. Replace battery and download data
ALM REG ● ●	Red and Green single flash every 60 sec. --Logger memory full	Download data

Operating instructions

1. Setup the DataLogger by software before use it.
2. Under the Manual mode, press and hold the button for 2s, DataLogger start to measure, and LED indicates the function at the same time.(see LED FLASH INDICATION for details.)
3. Under the Automatic mode, the DataLogger start to measure after setup in software, LED indicate the function at the same time.(see LED FLASH INDICATION for details.)
4. Under the Real-time FFT mode, the data update automaticly ,the latest FFT data will be stored.
5. During measurement, the green LED indicates the working state by flashing with the frequency setup in the software.
6. When datalogger memory full, Red LED and Green will flash every 60 sec .
7. As the battery power is not sufficient, red LED will flash every 30 sec for indication.
8. Press and hold the button for 2s untill Red LED sequently flash four times, and then logging will stop,or connect the datalogger to the host and download the data,the datalogger will stop automaticly.
9. DataLogger data can be read time after time, the readings you are checking are the real time measured ones. (1 to 85764 readings) ;if set the datalogger the last data will be losed.
10. Without battery, the latest 1 hours (the most) data will be lost. Other data can be read in software after battery is installed.
11. When replacing the battery, turn off the meter and open the battery cover. Replace the empty battery with a new 1/2AAA 3.6V battery and go for the cover.

Installation instructions

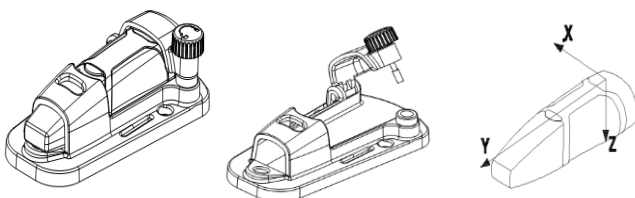

You have to fix the datalogger to the object rigidly,there are three ways as follow:

1. **Screw Install**
Fix the pedestal with three Screws , if screws is permitted in your application, this way will be preferable.
2. **Glue Install**
Fix the pedestal with glue,wait for the pedestal is tightly stucked to the object.
3. **Magnet Install**
Connect the pedestal and the object with magnetism, this way need the object can be absorbed with a magnet.

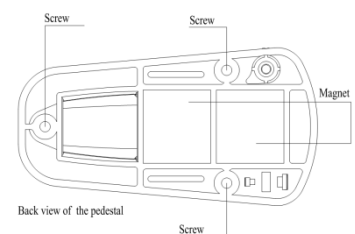

Notice

1. Do not store or operate the instrument at high temperature and high humidity environment.
2. When not in use for long time, please take out the battery to avoid battery liquid leakage and cautery on the instrument
3. Without battery, the latest 1 hours (the most) data will be lost.
4. The logger will log peak value of vibration/shock during sampling interval.
5. You have to setup the DataLogger by software before use it.
6. For the affection of gravity, You have to start the logger after fix the logger tightly to the object. otherwise the three axis X,Y,Z will not be calibrate correctly.

Software installation and operation

1. Start windows
2. Insert the CD into the CD-ROM
3. Run SETUPGUIDE.EXE installation program in file DISK1, install it to the directory of C:\Program Files\Vibration Datalogger.
4. After finishing the Vibration Datalogger software installation, this window will pop-up

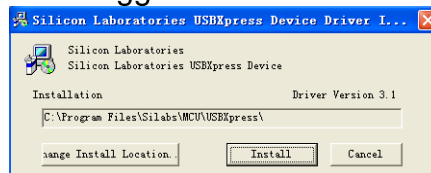

Click “Install” to finish the driver installation. After a successful installation of software and drivers, you can run the Vibration Datalogger software and communicate with the meter.

5. Double click the icon “

- The Sampling Setup field instructs the DATA LOGGER to log readings at a specific rate . You can input specific sampling rate data at the left Combo box and select the time unit at the right Combo box.
- The Motion Detection Threshold Setup filed allows the user to set the acceleration detection threshold. Once the acceleration value is over the threshold, the DATALOGGER will work.

- The LED Flash Cycle Setup field can be set 10s/20s/30s by the user depending on the requirement. By selecting “No Light” option, there will be no flash there by increase the battery life.
- The DATA LOGGER Record Mode can be set as Normal and Motion Detection.
- The Manual and Automatic select buttons allows the user to start data logging immediately when exit the Setup window(Automatic) or at a later time (Manual).

Click on the SETUP button to save changes. Press the DEFAULT button to set the Logger to factory default condition. Press the CANCEL button to abort the setup.

Notes: All stored data will be permanently erased when Setup is finished. To enable you to save the data before it is lost, click Cancel and then you need to download data. The battery might be exhausted before logger finish specified sample points. Always ensure that the remaining power in the battery is sufficient for completing your logging task. If in doubt, we recommend that you always install a fresh battery before logging critical data.

6. Download Data, To transfer the readings stored in the Logger to the PC:
Connect the DATA LOGGER to the USB port.

Open the Datalogger software program if it is not still running

Click the Download icon .

The Window shown below will appear. Click DOWNLOAD to begin transferring data



Once the data is successfully downloaded, the window shown below will appear.

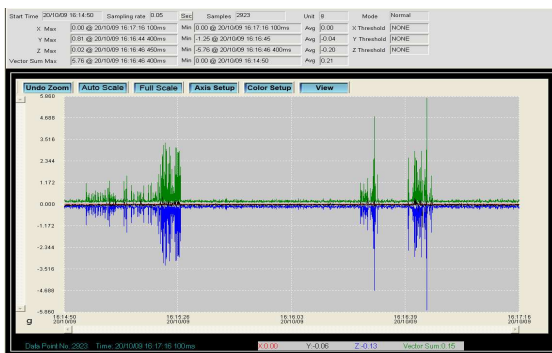

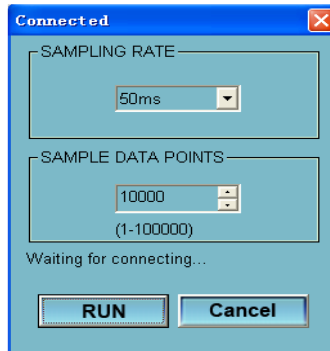

7. Run, Click  icon to read real-time data from the DATA LOGGER.



First, Setup the sampling rate and sample data points, then click RUN to start reading.

8. Reading for FFT Analysis 

Click  icon to read real-time spectral data for FFT analysis.

Click  to show the time-domain graph.



Click  to show the frequency-domain graph.

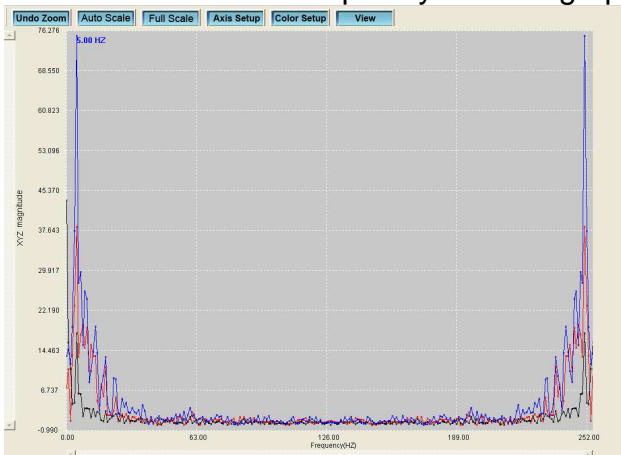

The software computes real-time spectral data using an FFT from 0 to 256 HZ.

The frequency of the max magnitude will be showed on this panel



Elma Instruments A/S
Ryttermarken 2
DK-3520 Farum
T: +45 7022 1000
F: +45 7022 1001
info@elma.dk
www.elma.dk

Elma Instruments AS
Garver Ytteborgsvei 83
N-0977 Oslo
T: +47 22 10 42 70
F: +47 22 21 62 00
firma@elma-instruments.no
www.elma-instruments.no

Elma Instruments AB
Pepparvägen 27
S-123 56 Farsta
T: +46 (0)8-447 57 70
F: +46 (0)8-447 57 79
info@elma-instruments.se
www.elma-instruments.se

TG: 22052013, ver 1.