

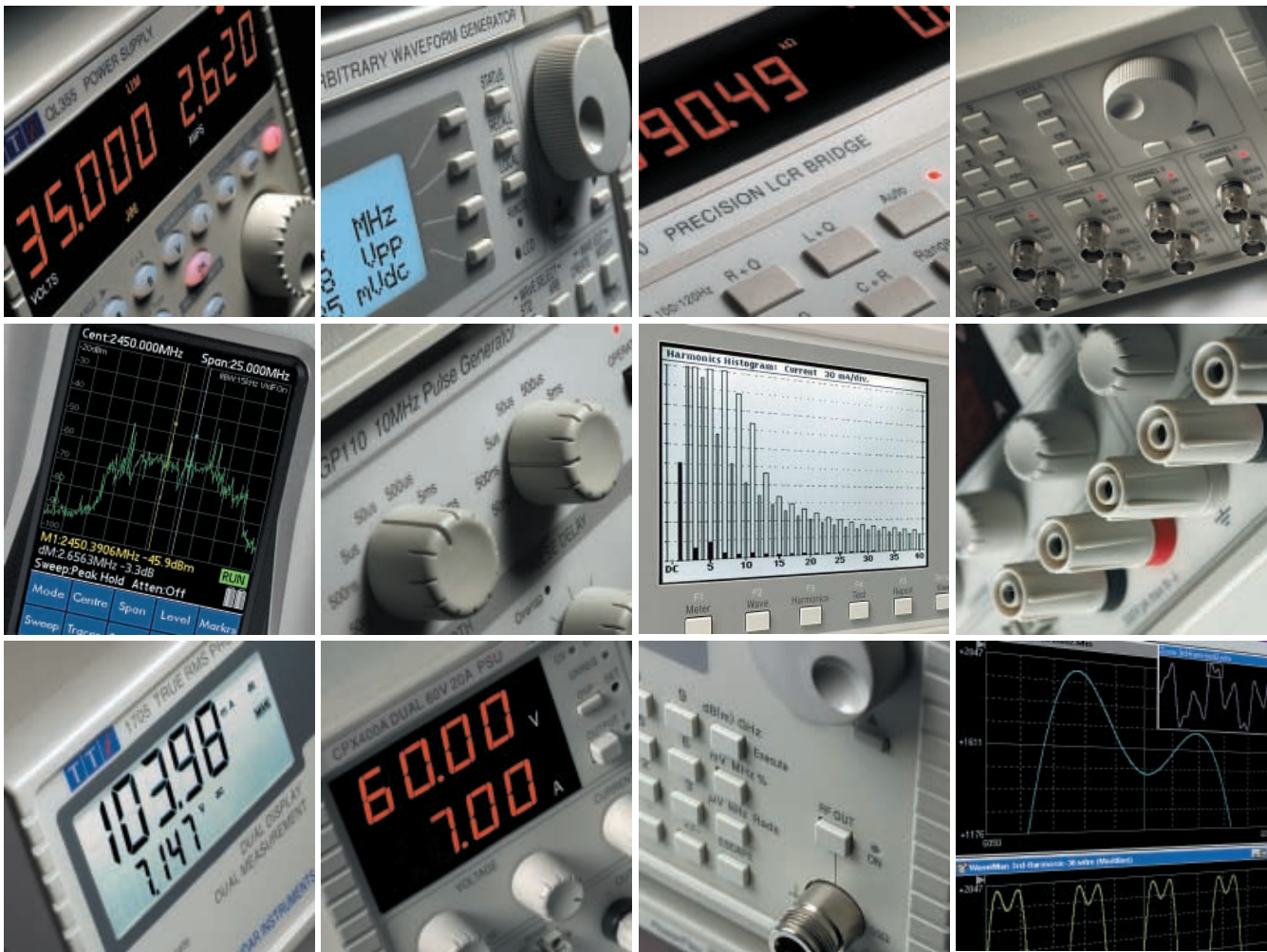

# THURLBY THANDAR INSTRUMENTS

## SHORTFORM CATALOGUE

### Test and Measurement Instruments



- Laboratory Power Supplies - manual and remote control •
- Waveform Generators - function, pulse and arbitrary •
- Precision Measurement Instruments •
- RF and EMC Test Equipment •

[tti-test.com](http://tti-test.com)

**ELSO**  
riešenia na presné meranie

Elso Philips Service  
Jilemnického 2; 911 01 Trenčín  
tel: +421 32 6582410, 7431690  
fax: +421 32 6582592  
email: [elso@elso.sk](mailto:elso@elso.sk)  
web: [www.elso.sk](http://www.elso.sk)

## Product Index

### Laboratory DC Power Supplies manual and bus programmable

Linear regulated power supplies	page 2
Mixed-mode regulated power supplies	page 5
PowerFlex regulated power supplies	page 7
Power supply selection table	page 9
(Electronic dc load	page 22)

### Waveform Generators arbitrary, function and pulse

Pulse generators	page 10
Waveform amplifiers	page 10
Arbitrary waveform software	page 11
Universal arbitrary generators	page 12
Digital function generators	page 14
Analog function generators	page 16

### Precision Measurement Instruments

Digital multimeters	page 18
LCR and micro-ohmmeters	page 20
Current measurement probe	page 21
Electronic dc load	page 22
Voltage proving unit	page 22
Frequency counters	page 23

### RF and EMC Test Equipment

RF power meters	page 24
Spectrum analyzers	page 25
Signal generators	page 26
Harmonics and flicker analyzer	page 27

### About this Short Form Catalogue

#### Products included

All of the main products that were available for sale at the time of printing have been included within this catalogue. Options and accessories are not necessarily included.

A full listing of current products, options and accessories is contained within the Price List which can be accessed from the web site.

#### New product introductions and changes

TTi regularly introduces new products and some may have been added since this catalogue was printed. For the latest information please visit our web site.

Products are subject to continuous development and changes to some detailed specifications or to cosmetic appearance may have taken place since the catalogue was printed.

#### Detailed product information

This catalogue contains only limited product information.

Fully detailed information for each product is available from the web site. Alternatively contact TTi or the local distributor in your country to request detailed information.

#### Product illustrations

The illustrations within this catalogue are representative of the products at the time of printing. The main illustration for each product is at approximately 42% (linear) of actual size in order to enable size comparisons.

Further illustrations within the product description area are at a variable scaling to fit the available space.

pages 1 - 9

pages 10 - 17

pages 18 - 23

pages 24 - 27



## Measurably better value

### About TTi

#### Excellence through experience

Thurlby Thandar Instruments is one of Europe's leading manufacturers of test and measurement instruments.

The company has wide experience in the design and manufacture of advanced test instruments and power supplies built up over nearly thirty years

TTi is based in the United Kingdom, and all products are built at the company's facility in Huntingdon, close to the famous university city of Cambridge.

#### Traceable quality systems



TTi is an ISO9001 registered company operating fully traceable quality systems for all processes from design through to final calibration.  
BS EN ISO9001:2000  
Certificate number FM 20695

### Where to buy TTi products

TTi products are widely available from a network of distributors and agents in more than fifty countries across the world.

To find your local distributor, please visit our web site which provides full contact details.

### The TTi Web site

Detailed product information is provided on the TTi web site, together with support information and price lists.

The main international web site for TTi products is: **tti-test.com**

This site can be accessed using the alternative web address: **tti.eu**

Customers within the UK can also use the web address: **tti.co.uk** which is the web site of our UK sales division.

(Note that a leading www. is optional for all of our web addresses)

The screenshot shows the TTi website interface. At the top, there is a navigation bar with the TTi logo and the text 'advanced electronic test instruments and laboratory power supplies'. Below this, there is a header section with the text 'TTi - the Home of Test and Measurement Electronic Test Instruments and Power Supplies from TTi - Thurlby Thandar Instruments'. The main content area features a grid of product categories: Laboratory Power Supplies, Waveform Generators, Precision Measurement Instruments, and RF and EMC Test Equipment. Each category is accompanied by an image of a representative product. At the bottom, there are two buttons: 'VIEW A SUMMARY OF ALL TTi PRODUCTS' and 'VIEW THE VERY LATEST PRODUCTS FROM TTi'.

**tti-test.com**

## Laboratory DC Power Supplies

### The technology leader

TTi is one of the world's major producers of laboratory power supplies (PSUs).

TTi has been a major technology innovator in PSUs since 1979 and now offers products ranging from 15 watts up to 1200 watts.

Hundreds of thousands of TTi power supplies are in everyday use around the world.

### Power technologies

TTi laboratory power supplies use both linear and switch-mode technologies in order to optimise performance and value for money.

#### Linear regulation

Pure linear regulation still provides the lowest output noise and best transient response. The disadvantage is greater physical size and weight for a given power, together with higher heat output.

#### Mixed-mode regulation

For higher power levels, TTi have developed a technology that uses switch-mode pre-regulation and linear final regulation. This technique combines exceptional efficiency with noise levels that are close to that of pure linears.

#### PowerFlex regulation

The TTi PowerFlex system uses a modified form of mixed-mode regulation to provide higher levels of current when the voltage is set to lower values.

Although producing slightly higher noise levels than the standard mixed-mode regulation, performance is still excellent.

### Measurement and control

#### Digital Metering

All TTi power supplies incorporate separate digital meters for voltage and current.

On most models these are 4 digit scale length with fixed resolution (e.g. 0.00V to 56.00V). Fixed resolution avoids the misinterpretation of readings that can occur with autoranging 3 or 3½ digit meters where the decimal point position moves as the reading changes.

QL and QPX models provide 5 digit meters for voltages to give still higher precision and resolution.

QL and New PL models also include a low current range which provides 0.1mA resolution.

#### Remote Sense

Most TTi power supplies incorporate remote sense terminals that can be enabled or disabled at the flick of a switch.

Remote sensing is essential to maintaining precise regulation at the load and true metering of the load voltage. Many other power supplies omit remote sense, but quote regulation figures that could never be achieved in a practice.

N.B. A 2 meter length of a 24/0.2 wire pair has a resistance of around 0.1 Ω. For a 5V load drawing 3A the metering error would be 0.3V and the effective full current load regulation would be around 6%, against a quoted figure of perhaps 0.01% for the power supply itself.

#### Output On/Off Switches

All TTi power supplies incorporate output on/off switches for the main outputs. This enables voltage and current settings to be viewed before the load is connected and allows multiple outputs to be controlled individually.

Many other power supplies omit this essential feature.

#### Analog or Digital Controls

TTi power supplies offer a choice of true analog controls or digital controls (numeric keyboard and/or spin-wheel).

The New PL Series combines true analog controls with advanced digital features such as S-Lock and V-Span.

The QL and QPX series offer 16-bit digital control and five digit metering with a resolution of 1mV.



### Bus programmable models

As well as the large range of manually controlled power supplies, TTi also offers many bus programmable units incorporating varying combination of RS-232, GPIB, USB and LAN interfaces.

LabView or LabWindows drivers are available for most power supplies.

### Silent Cooling

Most TTi power supplies use convection cooling thus removing the need for a fan and providing silent operation.

Certain models which offer particularly high power density (e.g. EX4210R) use fan-blown cooling to limit temperature rise in the power section.

Additionally, the QL series of high precision linear power supplies uses fan cooling to minimise power related temperature variation within the precision analog circuitry.

### Rack mounting

Many TTi PSU series, both bus programmable and manual, have a rack-modular casing size.

Rack mounts are available for the PL, QL, TSX, CPX, QPX and New PL series.

### Safety binding-post terminals

In response to changing customer requirements, TTi has introduced a new terminal design to most of the power supply range.

The new terminals accept a 4mm safety plug with rigid insulating sleeve, a requirement specified by an increasing number of laboratories for safety reasons.

However, unlike the usual 4mm safety sockets, the new TTi terminals can also accept fork connectors or bare wires, giving maximum flexibility.

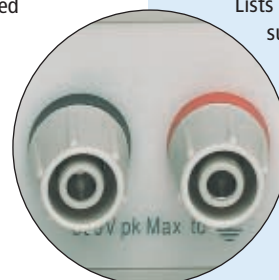

## Model ranges

### EL-R series - page 2

Compact linear regulated power supply series with analog controls. Single, dual and triple outputs. 30 to 130 watts  
RS-232 controlled model (EL302P).

### PL & PL-P series - page 2

Long established linear regulated power supply series. Single, dual and triple outputs. 65 to 235 watts.  
RS-232 and GPIB controlled models (PL-P).

### New PL & PL-P series - page 3

Advanced linear regulated power supply series with analog controls combined with digital functions. Ultra compact. Single and dual outputs. 75 to 180 watts.  
Models with RS-232, USB, and LAN (New PL-P). Optional GPIB.

### PLH & PLH-P series - page 3

Higher voltage versions of the New PL and PL-P series offering output voltages up to 250V. Single output, 90 watts.  
Models with RS-232, USB, and LAN (PLH-P). Optional GPIB.

### QL & QL-P series - page 4

High precision digitally controlled linear regulated power supply series with advanced features. Single and triple outputs. 105 to 220 watts.  
RS-232, USB, & GPIB controlled models (QL-P).

### TS series - page 4

Well established linear regulated power supply series. Single and dual outputs. 60 to 120 watts.

### EX-R series - page 5

Compact mixed-mode regulated power supply series with analog controls. Single, dual and triple outputs. 175 to 420 watts  
RS-232 controlled model (EX355P).

### TSX & TSX-P series - page 6

High performance mixed-mode regulated single output power supply series with analog or digital controls. 360 watts.  
RS-232 and GPIB controlled models (TSX-P).

### CPX series - page 7

Compact 'PowerFlex' regulated dual output series with analog controls. 350 to 840 watts.

### QPX series - page 8

High power 'PowerFlex' regulated power supplies with digital controls. 1200 watts. Analogue, RS-232 and USB interfaces standard. Optional LAN interface.

### Model selection chart - page 9

Lists all power supply models giving a summary of voltage, current, power and major features.

## Linear Regulation

Power supplies using all linear regulation offer the lowest output noise, the best transient response and the most benign stability characteristics when driving complex loads.

The disadvantage is greater physical size and weight for a given power, together with higher heat output. Linear regulation is used on the EL, EL-R, PL, QL and TS series.

## EL-R series

- ▶ Linear bench power supplies
- ▶ Single, dual or triple outputs
- ▶ 30W to 130W power range
- ▶ Switched remote sense terminals
- ▶ RS-232 interface model available

Dual output and triple output models are available using a similar casing style.

The EL302RT triple (illustrated) has a variable voltage auxiliary output which can be set using the digital displays. ▼

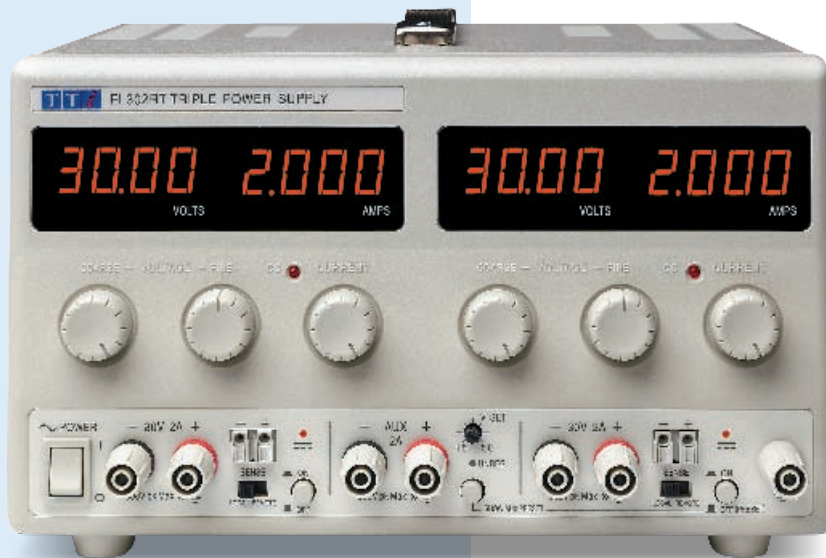

The EL-R series is the ideal solution for users requiring a good quality manual control, linear regulated bench power supply of low to medium power.

The series offers dual displays, high resolution control and metering, remote sensing, dc output switches and silent fan-free operation.

The EL302P includes an RS232 interface for those requiring a basic bus controllable power supply. ▶



Model	Outputs	Voltage / Current	Power	Interfaces
EL301R	One	0 to 30V / 0 to 1A	30W	-
EL183R	One	0 to 18V / 0 to 3.3A	60W	-
EL302R	One	0 to 30V / 0 to 2A	60W	-
EL302P	One	0 to 30V / 0 to 2A	60W	RS232
EL561R	One	0 to 56V / 0 to 1.1A	60W	-
EL155R	One	0 to 15V / 0 to 5A	75W	-
EL303R	One	0 to 30V / 0 to 3A	90W	-
EL302RD	Two	2 x (0 to 30V / 0 to 2A)	120W	-
EL302RT	Three	2 x (0 to 30V / 0 to 2A) plus 1.5 to 5V @ 2A	130W	-

Brief specifications for main outputs:

Line & load regulation: <0.01%. Output noise: < 1mV rms.

Meter accuracies: voltage - 0.3% ± 3digits, current - 0.5% ± 3digits.

Sizes: singles - 140 x 160 x 295mm; dual/triple - 260 x 160 x 295mm (WxHxD)

- ▶ Linear regulation provides low noise
- ▶ 4 digit voltage and current meters on each output \*
- ▶ Constant voltage or constant current operation
- ▶ Variable auxiliary output (1.5-5V@2A) on triple model
- ▶ Silent fan-free cooling
- ▶ DC output switches
- ▶ Low costs



\* Note that a 3 digit current meters is used on the EL302P, and that this model does not have remote sense terminals.

## Original PL & PL-P



The original PL series has been one of the most successful laboratory power supply product ranges of all time.

The products will remain available for a limited period of time, but are being replaced with the New PL series (see next page).

Model	Outputs	Voltage / Current	Power	Interfaces
PL154	One	0 to 15V / 0 to 4A	60W	-
PL320	One	0 to 32V / 0 to 2A	65W	-
PL330	One	0 to 32V / 0 to 3A	95W	-
PL320QMD	Two	2 x (0 to 32V / 0 to 2A)	130W	-
PL330QMD	Two	2 x (0 to 32V / 0 to 3A)	190W	-
PL320QMT	Three	2 x (0 to 32V / 0 to 2A) plus 4 - 6V @ 0 to 4A	155W	-
PL330QMT	Three	2 x (0 to 32V / 0 to 3A) plus 4 - 6V @ 0 to 7A	235W	-
PL330P	One	0 to 32V / 0 to 3A	95W	RS232/GPIB
PL330DP	Two	2 x (0 to 32V / 0 to 3A)	190W	RS232/GPIB
PL330TP	Three	2 x (0 to 32V / 0 to 3A) plus 4 - 6V @ 1 to 7A	235W	RS232/GPIB

Brief specifications for main outputs:

Line & load regulation: <0.01%. Output noise: < 1mV rms.

Meter accuracies: voltage - 0.1% ± 1digit, current - 0.3% ± 1digit.

Sizes: singles - 105 x 130 x 295mm; dual - 210 x 130 x 295mm (WxHxD)

- ▶ Linear regulated precision power supplies
- ▶ Wide model range, single, dual or triple outputs
- ▶ Twin 3 1/2 digit meters on each output
- ▶ Constant voltage or constant current operation

Model	Outputs	Voltage / Current	Power	Interfaces
PL155	One	0 to 15V / 0 to 5A	75W	-
PL303	One	0 to 30V / 0 to 3A	90W	-
PL601	One	0 to 60V / 0 to 1.5A	90W	-
PL303QMD	Two	2 x (0 to 30V / 0 to 3A)	180W	-
PL155P	One	0 to 15V / 0 to 5A	75W	RS232/USB/LAN
PL303P	One	0 to 30V / 0 to 3A	90W	RS232/USB/LAN
PL601P	One	0 to 60V / 0 to 1.5A	90W	RS232/USB/LAN
PL303QMDP	Two	2 x (0 to 30V / 0 to 3A)	180W	RS232/USB/LAN

Brief specifications for main outputs:  
 Line & load regulation: <0.01%. Output noise: < 0.4mV rms.  
 Meter accuracies: voltage - 0.1% ± 1digit, current - 0.3% ± 3 digits.  
 Sizes: singles - 105 x 130 x 290/315mm; dual - 210 x 130 x 290mm (WxHxD)

- ▶ Linear regulation provides ultra-low noise
- ▶ Highly compact (1/4 rack 3U) with small bench footprint
- ▶ True analog controls with advanced digital features
- ▶ Settings can be locked at the touch of a button
- ▶ 4 digit voltage and current meters on each output
- ▶ Low current range with 0.1mA resolution
- ▶ Constant voltage or constant current operation
- ▶ Independent, tracking or true parallel modes (PL303QMD)
- ▶ Front and rear power and sense terminals (PL-P models)
- ▶ Analog remote control (PL-P single output models)
- ▶ RS-232, USB and LAN/LXI interfaces (PL-P model)s

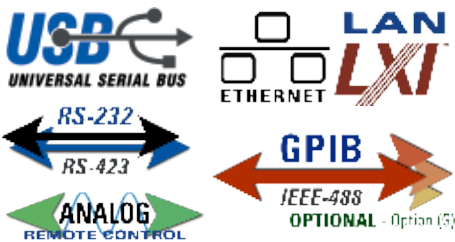

The New PL series is the latest power supply series from TTI and represents the successor to best-selling PL series.

This ultra-compact linear regulated design retains the traditional analog controls of the PL but adds important digital features.



When working with any piece of equipment, engineers tend to require a voltage source variable over only a narrow range.

That's where the V-Span function comes in. It allows the user to redefine the end-stop values of the voltage control to create a specific voltage range.

For example - An engineer is working on a circuit that will operate from four NiMH cells. They use V-Span to set a Vmax of 5.8 volts (to prevent over-voltage damage) and a Vmin of 3.6 volts (to ensure that the circuit doesn't reset).

They now have a power supply which provides high-resolution analog control over the exact voltage range they need.

The New PL-P series offers a comprehensive set of digital interfaces including RS232, USB and LAN (Ethernet) as standard, with GPIB optional.

The LAN interface is compliant with LXI-C. LXI (LAN eXtensions for Instrumentation) is the next-generation, modular architecture standard for automated test systems, and is expected to become the successor to GPIB in many systems.

## New PL & PL-P series

- ▶ High performance power supplies
- ▶ Linear regulation, 75W to 180W
- ▶ Manual or bus programmable
- ▶ RS-232, USB, LAN or GPIB



The New PL series is the solution for users requiring an advanced linear regulated precision bench power supply that retains conventional analog controls.

Its ultra-compact design uses minimal space on the bench or in the rack.

The New PL-P series offers the same manual control features but adds full remote control using analog, RS232, USB and LAN interfaces, the latter conforming with LXI.



For more information concerning LXI visit:

[www.tti-test.com/go/lxi](http://www.tti-test.com/go/lxi)

Model	Outputs	Voltage / Current	Power	Interfaces
PLH120	One	0 to 120V / 0 to 0.75A	90W	-
PLH250	One	0 to 250V / 0 to 0.36A	90W	-
PLH120-P	One	0 to 120V / 0 to 0.75A	90W	RS232/USB/LAN
PLH250-P	One	0 to 250V / 0 to 0.36A	90W	RS232/USB/LAN

Brief specifications for main outputs:  
 Line & load regulation: <0.01%. Output noise: < 0.4mV rms.  
 Meter accuracies: voltage - 0.1% ± 1digit, current - 0.3% ± 3 digits.  
 Size: PLH - 105 x 130 x 290mm; PLH-P - 105 x 130 x 315mm

The PLH series has been developed from the New PL series and retains all of its advanced features at output voltages of 120V or 250V.

Linear regulation offers the highest possible performance, and the compact quarter-rack width design provides an impressive 90 watts of power.

PLH-P series units have the same comprehensive set of interfaces as the New PL-P.



## PLH & PLH-P series

- ▶ High voltage versions of New PL
- ▶ Manual or bus programmable
- ▶ 90W power at 120V or 250V
- ▶ RS-232, USB, LAN or GPIB



**New Product**

The PLH series is available mid 2009

## QL & QL-P series

- ▶ High precision power supplies
- ▶ Single or triple outputs
- ▶ Linear regulation, 105W to 215W
- ▶ RS-232/GPIB/USB interfaces



The QL series represents the state-of-the-art in a linear regulated laboratory PSU.

Very high precision is matched by very low output noise. The digital user interface combines speed with safety.

Despite the compact dimensions, power is in excess of 100 watts per output, and multiple ranges provide higher current at lower voltages.

The triple output models incorporate two single output units plus an auxiliary low voltage output.

The two main outputs can be put into a linked mode for simultaneous or tracking control.

A master on/off system enables all three outputs to be switched synchronously. ▼

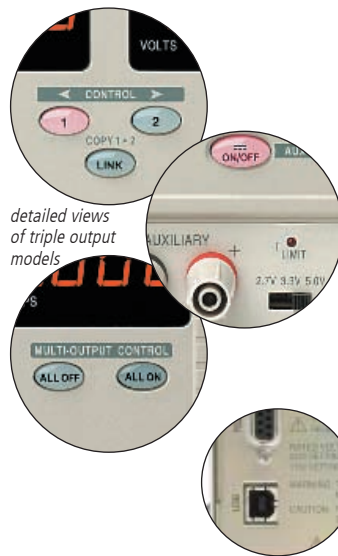

detailed views of triple output models

Model	Outputs	Voltage / Current	Power	Interfaces
QL355	One	0 to 35V / 0 to 3A or 0 to 15V / 0 to 5A	105W	-
QL564	One	0 to 56V / 0 to 2A or 0 to 25V / 0 to 4A	112W	-
QL355T	Three	2 x (0 to 35V / 0 to 3A or 0 to 15V / 0 to 5A) plus 2.7/3.3/5.0 @ 1A	215W	-
QL355P	One	0 to 35V / 0 to 3A or 0 to 15V / 0 to 5A	105W	RS-232/ USB/GPIB
QL564P	One	0 to 56V / 0 to 2A or 0 to 25V / 0 to 4A	112W	RS-232/ USB/GPIB
QL355TP	Three	2 x (0 to 35V / 0 to 3A or 0 to 15V / 0 to 5A) plus 2.7/3.3/5.0 @ 1A	215W	RS-232/ USB/GPIB

Brief specifications for main outputs:

Line & load regulation: <0.01%. Output noise: < 0.35mV rms.

Setting accuracies: voltage - 0.03% ± 5mV, current - 0.3% ± 0.5mA.

Sizes: singles - 141 x 172 x 300mm; triples - 282 x 172 x 300mm (WxHxD)

- ▶ Linear regulation with noise below 0.35mV rms
- ▶ 1mV setting resolution at all output voltages
- ▶ Setting by direct numeric entry or by spin wheel
- ▶ Multiple ranges for higher currents at lower voltages
- ▶ Multiple non-volatile setting memories with preview
- ▶ OVP and OCP trips with isolated alarm output
- ▶ Selectable remote sense for perfect regulation
- ▶ Linked-mode operation of main outputs (T models)
- ▶ Auxiliary output of 2.7/3.3/5.0V at 1A (T models)
- ▶ Compact modular width for bench or rack mounting
- ▶ GPIB (IEEE-488), RS232 & USB interfaces (P versions)
- ▶ Front and rear mounted output terminals (P versions)

QL-P versions are fitted with rear power and sense terminals together with digital bus control interfaces.

In addition to GPIB (IEEE-488) and RS-232, they include a USB interface for easy connection to a PC.

## TS series

- ▶ Manual bench power supplies
- ▶ Single, or dual outputs
- ▶ Linear regulation, 60W or 120W
- ▶ LCD displays

The TS series has been one of TTI's most successful products being in continuous production for more than 20 years.

Users appreciate its low noise design and all-metal construction.

It uses LCD displays and has remote sense terminals



Model	Outputs	Voltage / Current	Power	Interfaces
TS3021S	One	0 to 30V / 0 to 2A	60W	-
TS3022S	Two	2 x (0 to 30V / 0 to 2A)	120W	-

Brief specifications:

Line & load regulation: <0.01%. Output noise: < 1mV rms.

Meter accuracies: voltage - 0.1% ± 1digit, current - 0.3% ± 1digit.

Sizes: single - 160 x 160 x 245mm; dual - 308 x 160 x 245mm (WxHxD)

- ▶ Linear regulation provides low noise
- ▶ 3.5 digit autoranging LCD voltage and current meters
- ▶ Constant voltage or constant current operation
- ▶ Meter resolution 10mV and 1mA
- ▶ Remote sense terminals
- ▶ Silent fan-free cooling
- ▶ DC output switches



All-linear regulation becomes impractical at higher power levels, so TTI have developed a technology that combines HF switch-mode pre-regulation with linear final regulation.

This technique combines exceptional efficiency with noise levels that are close to that of pure linears. Mixed-mode regulation is used in the EX, EX-R and TSX series.

## Mixed-mode Regulation

Model	Outputs	Voltage / Current	Power	Interfaces
EX355R	One	0 to 35V / 0 to 5A	175W	-
EX355P	One	0 to 35V / 0 to 5A	175W	RS232
EX1810R	One	0 to 18V / 0 to 10A	180W	-
EX2020R	One	0 to 20V / 0 to 20A	400W	-
EX4210R	One	0 to 42V / 0 to 10A	420W	-
EX354RD	Two	2 x (0 to 35V / 0 to 4A)	280W	-
EX354RT	Three	2 x (0 to 35V / 0 to 4A) plus 1.5 to 5.0V @ 5A	305W	-
EX752M	Two	2 x (0 to 75V / 0 to 2A) or 0 to 75V / 0 to 4A or 0 to 150V / 0 to 2A	300W	-

Brief specifications for main outputs:  
Line & load regulation: <0.01%. Output noise: <2mV rms.  
Meter accuracies: voltage - 0.3% ± 1digit, current - 0.6% ± 1digit.  
Sizes: singles - 140 x 160 x 295mm; dual/triple - 260 x 160 x 295mm (WxHxD)

- ▶ Mixed-mode regulation with linear output stage
- ▶ 4 digit voltage and current meters on each output \*
- ▶ Constant voltage or constant current operation
- ▶ Variable auxiliary output (1.5-5V@5A) on triple model
- ▶ Switched remote sensing (not EX355P or EX752M)
- ▶ Silent fan-free cooling \*\*
- ▶ DC output switches

\* Note that 3 digit current meters are used on the EX355P and EX752M and that voltmeter resolution on the EX752M is 0.1V.

\*\* Note that the EX2020R and EX4210R use fan assisted cooling.



**Higher Voltage**  
up to **150V**

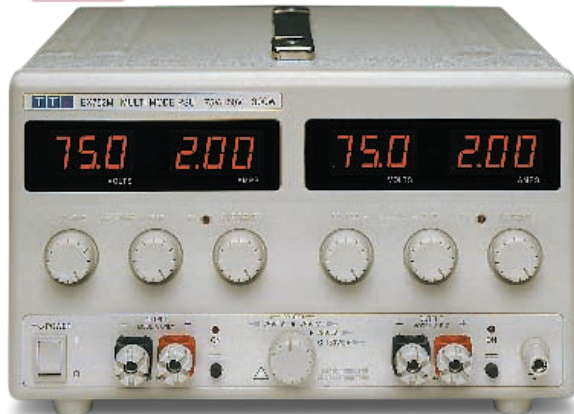

The EX series is the value-for-money PSU for users who require higher power levels. Mixed-mode regulation gives excellent performance combined with compact size and low weight.

Dual output and triple output models are available in a similar casing style.

The EX354RT triple (illustrated) has a variable voltage auxiliary output which can be set using the digital displays. ▼

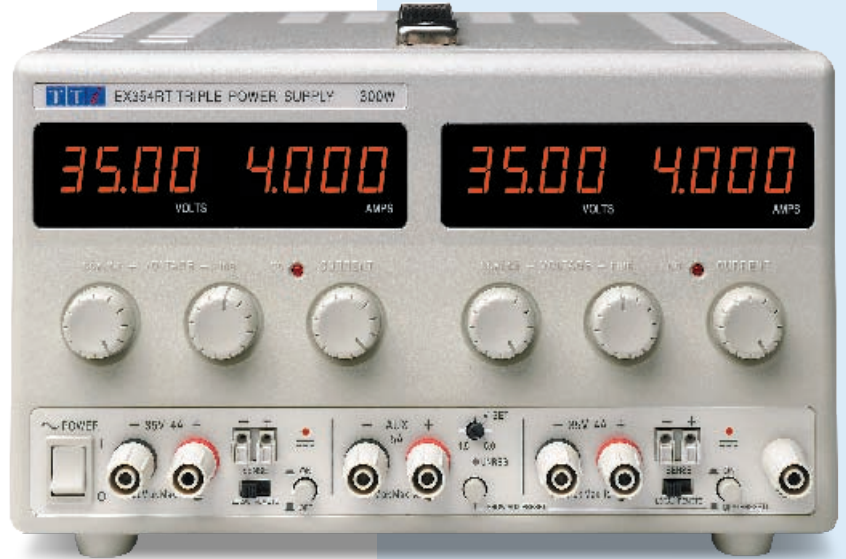

The EX-R series are single output power supplies similar in size and weight to the standard EX series but offering higher output currents.

To match their higher current capability, they include switchable remote sensing and extended voltmeter resolution. ▶

The EX355P includes an RS232 interface for those requiring a basic bus controllable power supply.

12 bit voltage setting resolution is matched by a 4 digit volts display. ◀

The EX752M is a dual output 300 watt PSU with Multi-Mode capability. This enables it to operate as a dual power supply with two independent and isolated outputs, or as a single power supply of double the power. ◀

As a dual, each output provides 0 to 75V at 0 to 2A (mode A). As a single, the output can be selected as either 0 to 75V at 0 to 4A (mode B) or 0 to 150V at 0 to 2A (mode C). In single modes, the unused half of the unit becomes completely inoperative and its displays are blanked.

## EX-R series

- ▶ Compact bench power supplies
- ▶ Single, dual or triple outputs
- ▶ Mixed-mode regulation
- ▶ Power from 175W to 420W
- ▶ Switched remote sense terminals
- ▶ RS-232 interface model available



**Higher Current**  
up to **20A**

## TSX series

- ▶ Mixed-mode regulation
- ▶ Very high performance
- ▶ Single output, 350W/360W
- ▶ Front and rear terminals

The TSX series is housed in a 3U half-rack size case suitable for bench use or rack mounting.

It uses silent convection cooling for the quietest possible working environment.

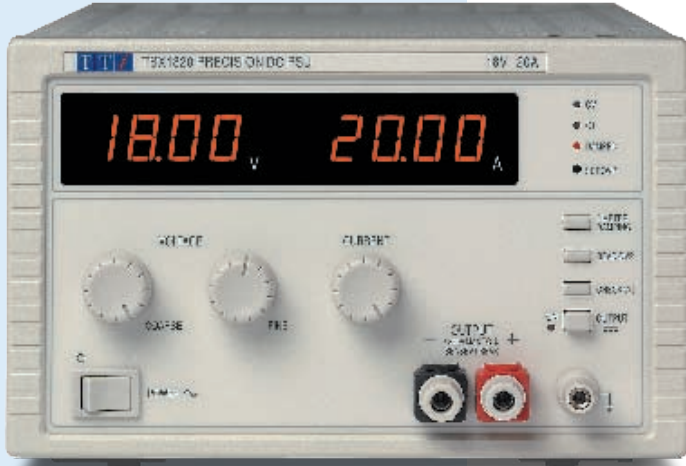

The TSX series offers exceptionally good noise and transient performance.

The switch-mode pre-regulation uses ultra low capacitance components to minimise common mode noise, while the linear final regulator minimises differential output noise.



Model	Outputs	Voltage / Current	Power	Interfaces
TSX1810	One	0 to 18V / 0 to 20A	360W	-
TSX3510	One	0 to 35V / 0 to 10A	350W	-

Brief specifications:  
Line and load regulation: <0.01%. Output noise: < 1mV rms.  
Meter accuracies: voltage - 0.2% ± 1digit, current - 0.5% ± 1digit.  
Size: 210 x 130 x 350mm (WxHxD). Weight: 5.0kg

- ▶ Choice of 35V/10A and 18V/20A models
- ▶ Very low noise, excellent transient response
- ▶ Constant voltage or constant current operation
- ▶ Comprehensive protection including OVP trip
- ▶ High setting resolution, remote sense terminals
- ▶ Bench or rack mounting, front and rear terminals
- ▶ Compact half-rack 3U case size

## TSX-P series

- ▶ Mixed-mode regulation
- ▶ Very high performance
- ▶ Fully digital control
- ▶ RS-232 and GPIB interfaces

The TSX-P series is housed in a 3U half-rack size case suitable for bench use or rack mounting.

It uses silent convection cooling for the quietest possible working environment.



The TSX-P is a digitally controlled version of the high performance TSX series.

It offers both keyboard and rotary control of setting along with a number of convenience features. It incorporates both RS-232 and GPIB interfaces.



Model	Outputs	Voltage / Current	Power	Interfaces
TSX1810P	One	0 to 18V / 0 to 20A	360W	RS232/GPIB
TSX3510P	One	0 to 35V / 0 to 10A	350W	RS232/GPIB

Brief specifications:  
Line and load regulation: <0.01%. Output noise: < 1mV rms.  
Meter accuracies: voltage - 0.2% ± 1digit, current - 0.5% ± 1digit.  
Size: 210 x 130 x 350mm (WxHxD). Weight: 5.0kg

- ▶ Power features as per TSX series (see above)
- ▶ Digital control with keyboard setting of all parameters
- ▶ Rotary and delta (step) control of voltage/current
- ▶ Third display for parameter indication including watts
- ▶ Non-volatile storage of up to twenty five settings
- ▶ Fully programmable with bus readback of V and I
- ▶ GPIB (IEEE-488) and addressable RS232 interfaces

Local operation convenience features of the TSX-P series include a auxiliary display for displaying other data such as increment values, OVP level, or watts.

The display is also used to preview entry from the keyboard in order to prevent errors.

Twenty five non-volatile memories are provided for storing frequently used settings. Each store holds a voltage, current and OVP setting.

The TTI PowerFlex system uses a modified form of mixed-mode regulation to provide higher levels of current when the voltage is set to lower values. Although producing slightly higher noise levels than

the standard mixed-mode regulation, performance is still excellent. PowerFlex regulation is used on the CPX and QPX series.

## PowerFlex Regulation

Model	Outputs	Voltage / Current	Power	Interfaces
CPX200	Two	2 x (0 to 35V / 0 to 10A*)	350W	-
CPX400A	Two	2 x (0 to 60V / 0 to 20A*)	840W	-

Brief specifications:  
 Line regulation: <0.01%. Load regulation: <0.02%. Output noise: < 3mV rms.  
 Meter accuracies: voltage - 0.2% ± 1digit, current - 0.5% ± 1digit.  
 Size: 210 x 130 x 350mm (WxHxD)  
 \* Note: maximum current is not available with maximum voltage see PowerFlex power envelope curves.

The CPX200 and CPX400A share the same compact case style.

The 350 watt CPX200 uses silent convection cooling while the 840 watt CPX400A uses fan assisted cooling.

## CPX series

- ▶ PowerFlex regulation
- ▶ Higher current at lower voltage
- ▶ Dual independent outputs
- ▶ 350 watts or 840 watts total

- ▶ PowerFlex design gives variable voltage and current combinations within a maximum power range
- ▶ Isolated outputs can be wired in series or parallel
- ▶ Constant voltage or constant current operation
- ▶ Variable OVP trips
- ▶ Selectable remote sense terminals
- ▶ Compact half-rack 3U case size

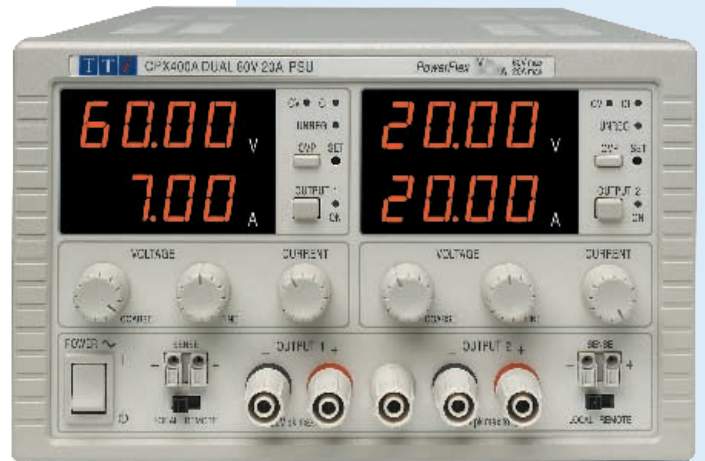
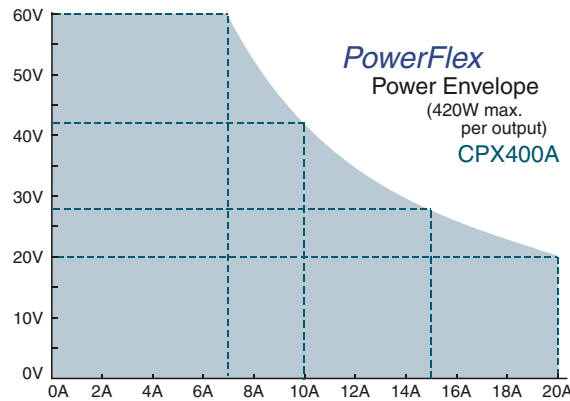
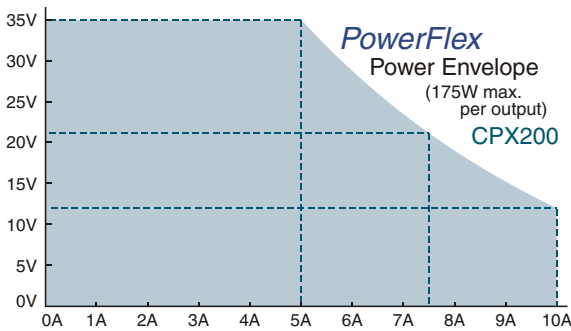

The CPX series is a different type of laboratory power supply designed to meet the need for flexibility in the choice of voltage and current.

Today's engineers often need a wide voltage range capability and a high current capability. Normally, however, the maximum voltage and maximum current are not required simultaneously.

A conventional PSU has a fixed current limit giving a power capability that reduces directly with the output voltage.

The TTI PowerFlex design of the CPX series enables higher currents to be generated at lower voltages within an overall power limit envelope.



## QPX1200L

- ▶ 1200 watts PowerFlex
- ▶ Higher currents at lower voltages
- ▶ 0 to 60 volts, 0 to 50 amps
- ▶ Analog, RS-232, USB & LAN (LXI)
- ▶ GPIB interface optional

Model	Outputs	Voltage / Current	Power	Interfaces
QPX1200L	One	0 to 60V / 0 to 50A*	1200W	RS232/USB/LAN
Option G				adds GPIB
Brief specifications:				
Line & load regulation: <0.01%. Output noise: < 3mV rms.				
Setting accuracies: voltage - 0.1% ± 2mV, current - 0.3% ± 20mA.				
Size: 350 x 130 x 415mm (WxHxD)				
* Note: max. current is not available with max. voltage, see PowerFlex curve.				

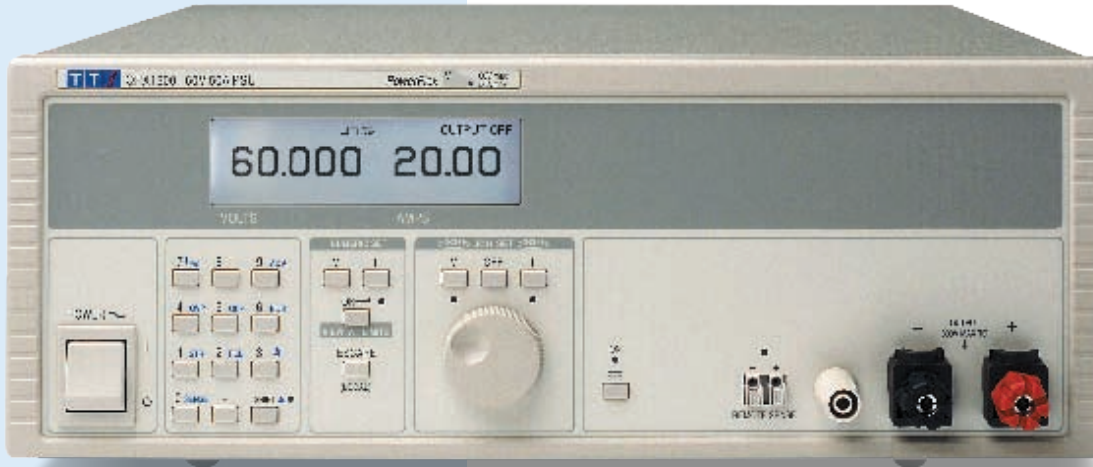

With a current capability of 20 amps at the maximum output of 60 volts, the PowerFlex design offers increasing output current with reducing output voltage.

Example voltage/current combinations include 60V/20A, 48V/25A, 37.5V/30A, 26V/40A, and 20V/50A.

The QPX1200L has analog, RS232 USB and LAN interfaces as standard. The latter conforms with the LXI standard

An optional GPIB interface can be specified.

The QPX1200 offers users a level of flexibility that cannot be achieved with conventional laboratory power supplies.

It can therefore perform the task of many different power supplies.

The QPX1200 is suited to be bench-top and system applications with front and rear terminals and a wide range of interfaces.

- ▶ PowerFlex design gives variable voltage/current combinations
- ▶ Up to 60 volts and up to 50 amps within a power envelope
- ▶ Setting by direct numeric entry or by spin wheel
- ▶ High setting resolution of 1mV in up to 60 volts
- ▶ Very low noise of < 3mV rms at full power
- ▶ Bench or rack mounting (3U) with front and rear terminals
- ▶ Analog, RS232, USB and LAN interfaces standard, GPIB option



LAN eXtensions for Instrumentation

For more information concerning LXI visit:

[www.tti-test.com/go/lxi](http://www.tti-test.com/go/lxi)

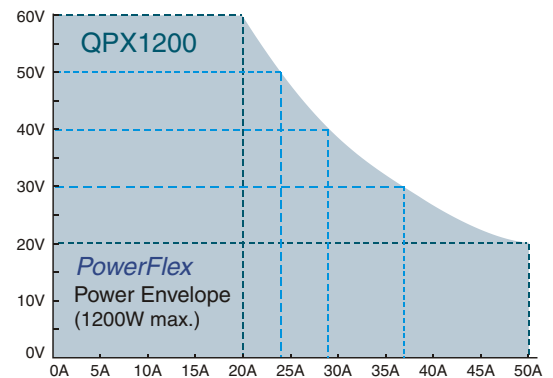

**Power Supply Selector**

MANUAL CONTROL MODELS												
Model No	Type	Regulation	O/Ps	Main Output(s)	Aux. Output	Power	R.Sense	Fan	Controls	Meters	Size mm	Weight
EB2025T	Basic	Linear	Triple	0.3 - 20V / 0 - 0.25A	5V @ 1A	15W	No	No	Analog	Analog	220x82x230	1.8kg
EL301R	Precision	Linear	Single	0 - 30V / 0 - 1A		30W	Yes	No	Analog	4 digit LED	140x160x195	3.4kg
EL183R	Precision	Linear	Single	0 - 18V / 0 - 3.3A		60W	Yes	No	Analog	4 digit LED	140x160x195	4.4kg
EL302R	Precision	Linear	Single	0 - 30V / 0 - 2A		60W	Yes	No	Analog	4 digit LED	140x160x195	4.4kg
EL561R	Precision	Linear	Single	0 - 56V / 0 - 1.1A		60W	Yes	No	Analog	4 digit LED	140x160x195	4.4kg
EL155R	Precision	Linear	Single	0 - 15V / 0 - 5A		75W	Yes	No	Analog	4 digit LED	140x160x195	5.0kg
EL303R	Precision	Linear	Single	0 - 30V / 0 - 3A		90W	Yes	No	Analog	4 digit LED	140x160x195	5.0kg
EL302RD	Precision	Linear	Dual	0 - 30V / 0 - 2A		120W	Yes	No	Analog	4 digit LED	260x160x195	7.5kg
EL302RT	Precision	Linear	Triple	0 - 30V / 0 - 2A	1.5 - 5V @ 2A	130W	Yes	No	Analog	4 digit LED	260x160x195	7.5kg
EX1810R	Precision	Mixed Mode	Single	0 - 18V / 0 - 10A		180W	Yes	No	Analog	4 digit LED	140x160x195	3.0kg
EX355R	Precision	Mixed Mode	Single	0 - 35V / 0 - 5A		175W	Yes	No	Analog	4 digit LED	140x160x195	3.0kg
EX2020R	Precision	Mixed Mode	Single	0 - 20V / 0 - 20A		400W	Yes	Yes	Analog	4 digit LED	140x160x195	3.5kg
EX4210R	Precision	Mixed Mode	Single	0 - 42V / 0 - 10A		420W	Yes	Yes	Analog	4 digit LED	140x160x195	3.5kg
EX354RD	Precision	Mixed Mode	Dual	0 - 35V / 0 - 4A		280W	Yes	No	Analog	4 digit LED	260x160x195	4.3kg
EX354RT	Precision	Mixed Mode	Triple	0 - 35V / 0 - 4A	1.5 - 5V @ 5A	305W	Yes	No	Analog	4 digit LED	260x160x195	4.3kg
EX752M	Multi-Mode HV	Mixed Mode	Dual	0 - 75V / 0 - 2A		300W	No	No	Analog	3 digit LED*	260x160x195	4.4kg
PL155	Advanced	Linear	Single	0 - 15V / 0 - 5A		75W	Yes	LN	Smart Analog	4 digit LED	105x130x295	4.5kg
PL303	Advanced	Linear	Single	0 - 30V / 0 - 3A		90W	Yes	LN	Smart Analog	4 digit LED	105x130x295	4.5kg
PL601	Advanced	Linear	Single	0 - 60V / 0 - 1.5A		90W	Yes	LN	Smart Analog	4 digit LED	105x130x295	4.5kg
PL303QMD	Advanced	Linear	Dual	0 - 30V / 0 - 3A		180W	Yes	LN	Smart Analog	4 digit LED	210x130x295	9.0kg
PLH120	Advanced HV	Linear	Single	0 - 120V / 0 - 0.75A		90W	Yes	LN	Smart Analog	4 digit LED	105x130x295	4.5kg
PLH250	Advanced HV	Linear	Single	0 - 250V / 0 - 0.36A		90W	Yes	LN	Smart Analog	4 digit LED	105x130x295	4.5kg
PL154	Precision	Linear	Single	0 - 15V / 0 - 4A		60W	Yes	No	Analog	4 digit LED	155x170x265	5.0kg
PL320	Precision	Linear	Single	0 - 32V / 0 - 2.1A		65W	Yes	No	Analog	4 digit LED	155x170x265	5.0kg
PL330	Precision	Linear	Single	0 - 32V / 0 - 3.1A		95W	Yes	No	Analog	4 digit LED	155x170x300	6.0kg
PL320QMD	Precision	Linear	Dual	0 - 32V / 0 - 2.1A		130W	Yes	No	Analog	4 digit LED	350x170x265	9.5kg
PL330QMD	Precision	Linear	Dual	0 - 32V / 0 - 3.1A		190W	Yes	No	Analog	4 digit LED	350x170x300	12.0kg
PL320QMT	Precision	Linear	Triple	0 - 32V / 0 - 2.1A	4 - 6V / 0 - 4A	155W	Yes	No	Analog	4 digit LED	425x170x265	13.5kg
PL330QMT	Precision	Linear	Triple	0 - 32V / 0 - 3.1A	4 - 6V / 0 - 7A	230W	Yes	No	Analog	4 digit LED	425x170x300	15.5kg
TS3021S	Precision	Linear	Single	0 - 30V / 0 - 2A		60W	Yes	No	Analog	3½ dig LCD	160x160x238	4.9kg
TS3022S	Precision	Linear	Dual	0 - 30V / 0 - 2A		120W	Yes	No	Analog	3½ dig LCD	308x160x238	9.6kg
QL355	High Precision	Linear	Single	0 - 35V / 0 - 5A #		105W	Yes	Yes	Digital	5 digit LED	141x171x300	5.0kg
QL564	High Precision	Linear	Single	0 - 56V / 0 - 4A #		112W	Yes	Yes	Digital	5 digit LED	141x171x300	5.0kg
QL355T	High Precision	Linear	Triple	0 - 35V / 0 - 5A #	2.7V-5V @ 1A	215W	Yes	Yes	Digital	5 digit LED	282x171x300	10.0kg
TSX1820	Precision	Mixed Mode	Single	0 - 18V / 0 - 20A		360W	Yes	No	Analog	4 digit LED	210x130x350	5.0kg
TSX3510	Precision	Mixed Mode	Single	0 - 35V / 0 - 10A		350W	Yes	No	Analog	4 digit LED	210x130x350	5.0kg
CPX200	Precision	PowerFlex	Dual	0 - 35V / 0 - 10A †		350W	Yes	No	Analog	4 digit LED	210x130x350	6.0kg
CPX400A	Precision	PowerFlex	Dual	0 - 60V / 0 - 20A †		840W	Yes	Yes	Analog	4 digit LED	210x130x350	7.5kg
BUS PROGRAMMABLE MODELS (Manual and Remote Control)												
Model No	Interfaces	Regulation	O/Ps	Main Output(s)	Aux. Output	Power	R.Sense	Fan	Local Cntrl	Meters	Size mm	Weight
EL302-P	RS-232	Linear	Single	0 - 30V / 0 - 2A		60W	No	No	Digital	4 digit LED*	140x160x195	4.4kg
EX355-P	RS-232	Mixed Mode	Single	0 - 35V / 0 - 5A		175W	No	No	Digital	4 digit LED*	140x160x195	3.0kg
PL155-P	RS-232/USB/LAN	Linear	Single	0 - 15V / 0 - 5A		75W	Yes	LN	Smart Analog	4 digit LED	105x130x295	4.7kg
PL303-P	RS-232/USB/LAN	Linear	Single	0 - 30V / 0 - 3A		90W	Yes	LN	Smart Analog	4 digit LED	105x130x295	4.7kg
PL601-P	RS-232/USB/LAN	Linear	Single	0 - 60V / 0 - 1.5A		90W	Yes	LN	Smart Analog	4 digit LED	105x130x295	4.7kg
PL303QMD-P	RS-232/USB/LAN	Linear	Dual	0 - 30V / 0 - 3A		180W	Yes	LN	Smart Analog	4 digit LED	210x130x295	9.2kg
PLH120-P	RS-232/USB/LAN	Linear	Single	0 - 120V / 0 - 0.75A		90W	Yes	LN	Smart Analog	4 digit LED	105x130x295	4.5kg
PLH250-P	RS-232/USB/LAN	Linear	Single	0 - 250V / 0 - 0.36A		90W	Yes	LN	Smart Analog	4 digit LED	105x130x295	4.5kg
PL330-P	RS-232 & GPIB	Linear	Single	0 - 32V / 0 - 3.1A		95W	Yes	No	Analog	4 digit LED	207x170x300	6.5kg
PL330D-P	RS-232 & GPIB	Linear	Dual	0 - 32V / 0 - 3.1A		190W	Yes	No	Analog	4 digit LED	350x170x300	12.5kg
PL330T-P	RS-232 & GPIB	Linear	Triple	0 - 32V / 0 - 3.1A	4 - 6V / 1 - 7A	230W	Yes	No	Analog	4 digit LED	425x170x300	16.0kg
QL355-P	USB/RS232/GPIB	Linear	Single	0 - 35V / 0 - 5A #		105W	Yes	Yes	Digital	5 digit LED	141x171x300	5.0kg
QL564-P	USB/RS232/GPIB	Linear	Single	0 - 56V / 0 - 4A #		112W	Yes	Yes	Digital	5 digit LED	141x171x300	5.0kg
QL355T-P	USB/RS232/GPIB	Linear	Triple	0 - 35V / 0 - 5A #	2.7V-5V @ 1A	215W	Yes	Yes	Digital	5 digit LED	282x171x300	10.0kg
TSX1820-P	RS-232 & GPIB	Mixed Mode	Single	0 - 18V / 0 - 20A		360W	Yes	No	Digital	4 digit LED	210x130x350	5.5kg
TSX3510-P	RS-232 & GPIB	Mixed Mode	Single	0 - 35V / 0 - 10A		350W	Yes	No	Digital	4 digit LED	210x130x350	5.5kg
QPX1200	RS-232/USB/LAN	PowerFlex	Single	0 - 60V / 0 - 50A †		1200W	Yes	Yes	Digital	5 digit LCD	350x130x 415	9.2kg

for full power supply  
technical information:  
[www.tti-test.com/psu](http://www.tti-test.com/psu)

## Product Range

### Pulse Generators - page 10

Analog 10MHz pulse generator.

### Waveform Amplifiers - page 10

Wide-band amplifier with 30V pk-pk output.

### Arbitrary Waveform Generators - page 11

Arbitrary waveform software, universal waveform generators (arbitrary/function/pulse) with up to four channels, and up to 100MS/s.

### Digital Function Generators - page 14

DDS based function generators, with and without arbitrary capability at frequencies up to 40MHz.

### Analog Function Generators - page 16

Dial-set and digital display function generators from 2MHz up to 20MHz. Models with sweep and external frequency measurement.

### RF Signal Generators

See RF section (page 26)

## Function, Arbitrary & Pulse generators

TTI is a world leader in waveform generation with products ranging from basic analog function generators through to advanced multi-channel arbitrary generators.

### Waveform quality

The success of TTI function generators has always been based around waveform quality.

TTI generators offer waveform quality not just at high output levels, but at low levels as well - a much more difficult task.

Careful analog design yields excellent waveform purity at all frequencies and levels, unlike many competitive products.

### Digital architectures

TTI has been at the forefront of digital generator design with products that combine both DDS (direct digital synthesis) and variable-clock architectures in order to offer superior performance.



## TGP110 Pulse Generator

- ▶ 0.1Hz to 10MHz pulse generator
- ▶ Very wide pulse control range



The TGP110 is an analog pulse generator that offers a very wide control range. Its dedicated architecture enables it to generate fast rise time flat top pulses over a very large duty cycle range.

The unit offers selectable delay between trigger and pulse, or between two pulses in double pulse mode. A sync output signal provides a pulse in synchronism with the trigger.

A low impedance output of fully variable level is provided together with a TTL/CMOS output and a level inversion switch.

- ▶ 0.1Hz to 10MHz frequency range
- ▶ Independent control of pulse frequency, width and delay
- ▶ 50ns minimum pulse width
- ▶ Squarewave, double pulse and delayed pulse modes
- ▶ Free-run, gated and triggered modes
- ▶ 50 Ohm output: 0.1V to 10V amplitude
- ▶ TTL/CMOS and Sync outputs

## WA301 Waveform Amplifier

- ▶ Up to 30 volts pk-pk output
- ▶ DC to 1 MHz bandwidth



The WA301 wide-band waveform amplifier is intended for extending the maximum output voltage swing of function and arbitrary generators for applications where an EMF of 20 volts pk-pk is insufficient.

- ▶ 30 V pk to pk output (15 V into terminating impedance)
- ▶ 50Ω and 600Ω outputs; full output protection
- ▶ Switchable 20dB output attenuator
- ▶ DC to 1MHz bandwidth
- ▶ High impedance input; 0dB to +20dB gain

## Arbitrary generator architectures

### Using Waveform Sequencing to increase waveform length

Variable clock architecture allows waveform sequencing and looping. The 64K words of waveform memory provided in TGA1240 series can be used to create arbitrary waveforms with many more than 65536 points. Many real-world waveforms include repetitive elements. By using a segment of the memory to recreate each repeating element, the waveform can be constructed by a 'sequence' in which the individual elements are played in a defined order and with a defined number of repetitions (loop count). In this way waveforms can be created with a much greater number of points than the waveform memory size.

DDS arbitrary generators cannot do this and the effective waveform length is limited to the actual waveform memory size.

### Universal Architecture

Although variable clock waveform generation offers many advantages when generating arbitrary waveforms, the DDS system has important advantages when frequency sweep or other frequency modulation is required, because it offers better frequency agility and automatic control of the effective waveform length.

The universal architecture of the TGA series offers the best possible performance by incorporating the advantages of both variable clock and DDS architectures within the same instrument.

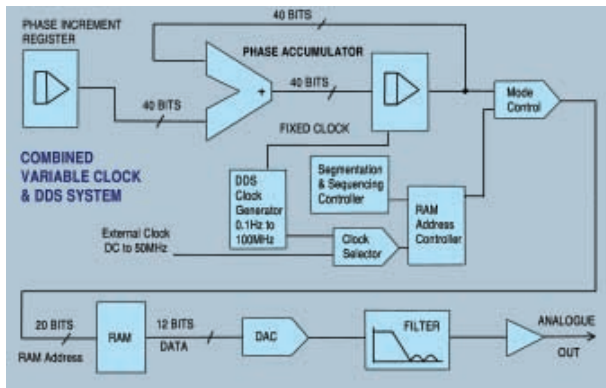

### Avoiding Waveform Jitter

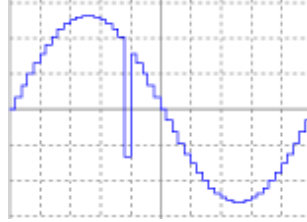

Glitched sine wave created in fifty points for replay at circa 1MHz repetition rate.

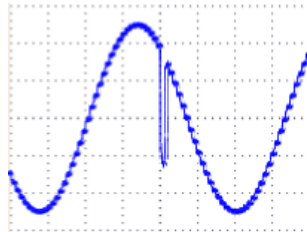

Waveform replayed at 950kHz repetition rate on 100MS/s DDS generator (output filter off). Note 10ns jitter visible on glitch.

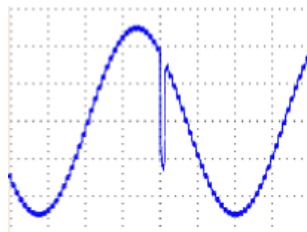

Waveform replayed at 950kHz repetition rate on 100MS/s variable clock generator (output filter off). For more information go to: [www.tti-test.com/go/arb](http://www.tti-test.com/go/arb)

Before purchasing a generator intended for arbitrary waveform use, it is important to discover what technology it uses - variable clock or DDS.

A variable clock arbitrary generator provides a fully variable clock frequency to read the data out of the waveform memory. This system can faithfully reproduce the stored waveform at any repetition rate within the limits of its maximum and minimum clock frequencies.

In a DDS arbitrary generator the clock frequency is fixed and the repetition rate of the stored waveform is varied by changing the addressing interval. This system only faithfully reproduces a waveform at a repetition rate equal to the DDS clock frequency divided by the waveform length (or sub-multiples of this). At all other frequencies samples are either omitted or are duplicated an uneven number of times. For repetitive waveforms this results in clock jitter.

DDS arbitrary generators also provide no facility for waveform sequencing - a technique that facilitates the construction of long and complex arbitrary waveforms that can be much longer than the waveform store length.

Some manufacturers, who offer both types of generator, refer to DDS arbitrary generators as AFGs (arbitrary function generators) and to variable clock generators as AWGs (arbitrary waveform generators). However, other manufacturers give no indication of the technology used.

For a detailed explanation of differences between the DDS and variable-clock architectures for generators - go to our web site:

[www.tti-test.com/go/arb](http://www.tti-test.com/go/arb)

## Waveform Manager Plus software

TTi arbitrary generators include a built-in waveform creation/editing facility that includes point-by-point value insertion, straight line interpolation between points and standard waveform insertion between points.

However, complex arbitrary waveforms will need to be generated using sophisticated software tools outside of the instrument and transferred using the digital interfaces.

Waveform Manager Plus is a Windows program that offers the most comprehensive range of waveform creation and editing tools available including a full mathematical expression generator and freehand drawing tools.

Waveform Manager Plus is supplied as standard with all TGA series generators and with the TG4001.

Waveform Manager Plus can also be used to import waveforms from other software programs or other hardware devices and to scale and crop these waveforms for compatibility with the target arbitrary generator.

- ▶ Full waveform building tools including standard waveforms, mathematical expressions, clipboard functions and freehand drawing.
- ▶ Compatible with OSs from Win95 through to Vista.
- ▶ Vertical resolutions up to 16 bits (65536 points).
- ▶ Horizontal resolutions to over one million points.
- ▶ Waveform import/export via clipboard functions.
- ▶ Download and upload via RS-232, GPIB and USB..

*Waveform Manager Plus is supplied with all TGA series generators and the TG4001. Full details of the software capabilities are available on the web site.*

- ▶ Waveform creation, editing, import and management
- ▶ Full waveform building tools
- ▶ Download via RS232, GPIB or USB

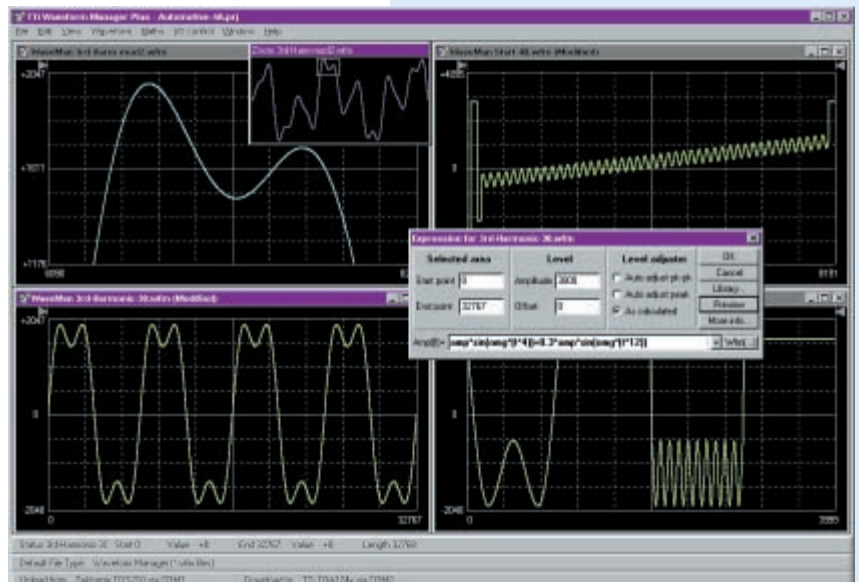

## ARB generator types

Arbitrary generator describes a class of digital generator potentially capable of reproducing any waveform shape. There are two distinctly different ways in which arbitrary waveforms can be produced - DDS and Variable Clock \*.

Because each manufacturer may choose a different description for their product, it is not easy to know which underlying technology is being used.

There are three broad classes of arbitrary waveform generator:

1. Generators that use DDS (direct digital synthesis) for the production of both standard waveforms (function generator mode) and arbitrary waveforms.

These are most commonly described as either Function/Arbitrary Generators or Arbitrary/Function Generators (AFG).

2. Generators that use a variable clock architecture for the production of both standard waveforms and arbitrary waveforms. Within these generators a standard waveform is simply a specific instance of an arbitrary waveform.

These are most commonly described as Arbitrary Waveform Generators (AWG)

3. Generators that use DDS for the production of standard waveforms (function generator mode) and variable clock for generating arbitrary waveforms.

These may be described as Universal Arbitrary Waveform Generators or simply Arbitrary Waveform Generators (AWG) as in category 2.

\* See page 11 for more information about arbitrary generator architectures.

## TGA overview

TTI generators with the TGA prefix are universal arbitrary waveform generators offering a choice of one, two or four channels.

Two series are available; the TGA1240 which has a maximum clock speed of 40MHz, and the TGA12100 which has a maximum clock speed of 100MHz, greater waveform memory length, and a number of additional features.

A key feature of both series is the universal architecture which combines the advantages of true variable clock arbitrary waveform generation with the benefits of DDS (direct digital synthesis) when acting as a function generator.

The two and four channel models offer exceptional flexibility with channels that can be fully independent or linked. In independent mode each channel is a completely separate generator offering not just differing frequency, amplitude and waveform but different operational modes.

For example one channels could be used as a function generator while another is used as an arbitrary generator and a third as a pulse generator.

The channels can be set to provide inter-channel triggering, modulation or summing. Alternatively they can be linked to offer multi-channel phase controlled signals.

Universal Arbitrary Waveform Generators - comparison table (see also TG series - page 14)			
	TGA1240 series	TGA12100 series	(TG4001)
Number of Channels	1, 2 or 4	1, 2 or 4	1
<b>Arbitrary Waveforms</b>			
Waveform Generation System	Variable Clock, 12 bit vertical resolution		
Clock Frequency Range	0.1Hz to 40MHz	0.1Hz to 100MHz	0.1Hz to 100MHz
External ARB Clock	No	DC to 50MHz	No
Waveform Length	4 to 65,536 points	8 to 1,048,576 points	4 to 65,536 points
Internal Waveform Storage	Up to 100 waveforms	Up to 500 waveforms	4 waveforms
Waveform Sequencing	Up to 16 waveforms	Up to 1024 waveforms	None
Arbitrary Waveform Editing	Internal or via Waveform Manager Plus software (supplied)		
<b>Standard Waveforms (function generator mode)</b>			
Waveform Generation System	DDS (Direct Digital Synthesis)		
Max. Frequency (sine/square)	16MHz/16MHz	40MHz/50MHz	40MHz/50MHz
Frequency Resolution (sine)	7 digits or 0.1mHz	10 digits or 0.1mHz	10 digits or 0.1mHz
Minimum Frequency	0.0001Hz	0.0001Hz	0.0001Hz
Frequency Accuracy	Better than $\pm 10$ ppm		
Waveform Functions	Sine, Square, Triangle, +ve/-ve Pulse, +ve/-ve Ramp, Pulse train, Cosine, Haversine, Haversine, Noise (not 1240 series).		
Sinewave Purity	<0.1% to 100kHz <-35dBc at 10MHz	<0.15% to 100kHz, typically <-35dBc at 40MHz	<0.15% to 100kHz, typically <-35dBc at 40MHz
<b>Modulations</b>			
Frequency Sweep (Range)	1mHz to 16MHz	1mHz to 40MHz	1mHz to 40MHz
Frequency Sweep (Rate/Mode)	30ms to 999s, lin or log	1ms to 999s, lin or log	1ms to 999s, lin or log
External AM/External Sum	Yes/Yes	Yes/Yes	Yes/No
Internal Trigger Generator	0.005 Hz to 100kHz		
Triggered Burst	1 to 1048575 cycles		
Variable Start-Stop Phase	0.1 degree resolution		
Other Modes	Gated, Tone Switching, FSK		
<b>Inter-channel Modes (2 and 4 channel models)</b>			
Channel Interactions	Inter-channel Modulation, Triggering, or Analogue Summing for any number of channels		-
Phase Locking	Any number of channels can be phase locked to 0.1 degree resolution plus 10ns uncertainty		-
<b>Output Characteristics</b>			
Amplitude Range (pk-pk EMF)	5mV - 20V from 50 $\Omega$ (display corrected for Hi-Z, 50 $\Omega$ or 600 $\Omega$ termination)		
DC Offset Range	$\pm 10$ V EMF		
Output Flatness	$\pm 0.2$ dB to 200kHz; $\pm 1$ dB to 10MHz; $\pm 2.5$ dB to 16MHz	$\pm 0.2$ dB to 1MHz; $\pm 0.4$ dB to 40MHz	$\pm 0.2$ dB to 1MHz; $\pm 0.4$ dB to 40MHz
<b>Other Features</b>			
Auxiliary Output(s)	Multi-function output for Waveform Sync, Trigger Out, Sweep Sync., Marker		
Reference Clock In/Out	Input for external fixed reference clock or output of internal reference clock. Can be used to phase lock two or more generators		
Instrument Set-up Storage	9 stores	Up to 500 stores	9 stores
Display	4 line backlit dot-matrix LCD		
Digital Interfaces	RS232/GPIB	RS232/USB/GPIB	RS232/USB (GPIB option)
Power: 230V or 115V AC nominal 50/60Hz, adjustable internally except for TGA12102/4 which are 100V to 230V, 50/60/400Hz. Size and weight: TGA1241, TGA12101 and TG4001 are 3U half-rack: 212 x 130 x 335 mm (WxHxD). 4.1 kg (9 lb). TGA1242 and TGA1244 are 3U full (5/6) rack: 350 x 130 x 335 mm (WxHxD). 7.1 kg (15.6 lb) TGA12102 and TGA12104 are 3U full (5/6) rack: 350 x 130 x 335 mm (WxHxD). 6.0 kg (13.2 lb)			

### Arbitrary, function and pulse

Each channel of a TGA series generator can be used as an arbitrary generator, function generator, or pulse pattern generator.

As a pulse generator a pattern of up to ten pulses can be defined with each pulse having its own amplitude, width and delay. The complete pattern can then be replayed at a user defined repetition rate.

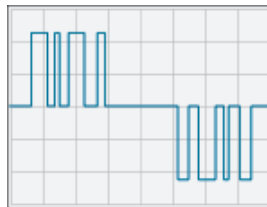

### Waveform sequencing

Sequencing enables complex waveforms to be constructed by sequencing simpler elements.

To understand the benefits of sequencing go to: [www.tti-test.com/go/arb](http://www.tti-test.com/go/arb)

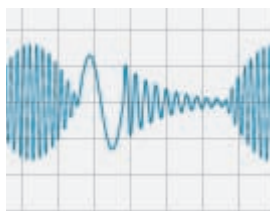

### Multi-channel phase locking

Multi-channel TGA series generators can be used to generate multi-phase signals

Any number of channels can be phase locked with offsets defined to a resolution of 0.1 degrees.

TGA12100 models can also be phase locked to an external reference clock and provide phase continuous frequency changes with a varying external signal.

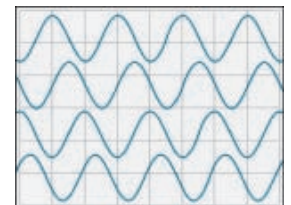

### Multi-channel modulation

Inter-channel modulation and summing allows the creation of complex modulation systems for simulation and testing.

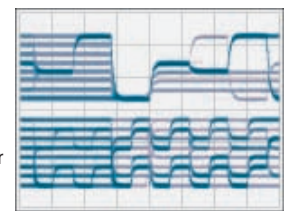

The TGA1240 series are universal arbitrary waveform generators that combine a high performance arbitrary waveform generator, pulse train generator and DDS function generator on each channel.

Variable clock architecture eliminates sampling jitter and enables complex waveforms to be created using waveform sequencing.

Multi-channel units can be operated as completely independent signal sources, phase locked sources, or interlinked sources using inter-channel triggering, modulation or summing.

- ▶ 1, 2 or 4 waveform channels, independent or linked.
- ▶ 40MS/s maximum sampling, (0.1Hz to 40MHz variable clock).
- ▶ 65,536 point waveform memory per channel.
- ▶ Non-volatile storage for up to 100 waveforms
- ▶ Complex waveform sequencing and looping capability.
- ▶ Inter-channel triggering, summing and phase control.
- ▶ 16MHz function generator capabilities using DDS.
- ▶ Multiple 'standard' waveforms including sine, square, triangle, haversine, ramp, pulse and sin(x)/x.
- ▶ Pulse train generation for up to 10 pulses.
- ▶ Wide range sweep, AM, tone switching, signal summing.
- ▶ Tone switching facilitates precision DTMF generation.
- ▶ Built-in trigger generator, gated & triggered burst modes.
- ▶ Fully interfaceable via RS-232 and GPIB (IEEE-488.2).

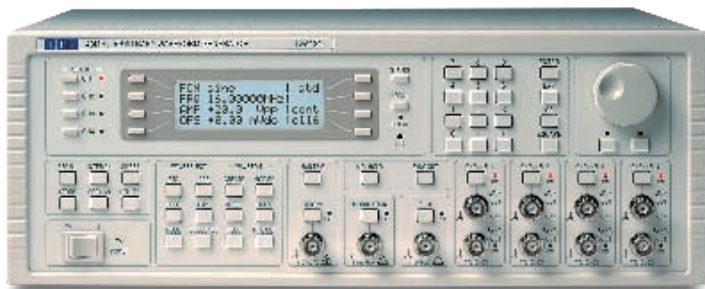

*Further details are provided in the comparison table opposite. Full details are available on the web site.*

## TGA1240 series

- ▶ 40MS/s universal arbitrary waveform generators
- ▶ One, two or four channels
- ▶ Variable clock ARB architecture
- ▶ DDS based function generator
- ▶ Independent or linked channels
- ▶ Pulse train generation
- ▶ RS-232 and GPIB interfaces

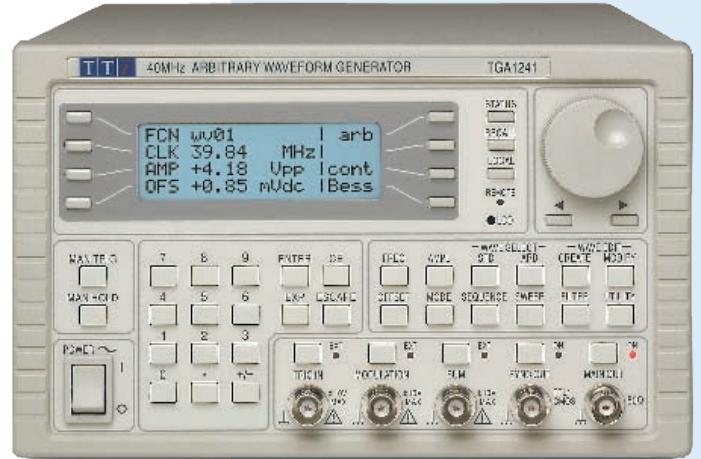

Model Range:  
 TGA1241 - single channel  
 TGA1242 - two channels  
 TGA1244 - four channels

Model Range:  
 TGA12101 - single channel  
 TGA12102 - two channels  
 TGA12104 - four channels



## TGA12100 series

- ▶ 100MS/s universal arbitrary waveform generators
- ▶ One, two or four channels
- ▶ 1M word waveform memory
- ▶ External ARB clock input
- ▶ Storage on CF memory cards
- ▶ RS-232, GPIB and USB interfaces

The TGA12100 series offers all of the features of the TGA1240 series with extended sampling speed and memory depth.

It also includes a number of additional features such as an external ARB clock input that extends the capabilities further.

- ▶ Features as per the TGA1240 series with the following additions:
- ▶ 100MS/s maximum sampling, (0.1Hz to 100MHz variable clock).
- ▶ 1,048,576 point waveform memory per channel.
- ▶ Waveform storage using removable CompactFlash memory cards.
- ▶ 40MHz function generator capabilities using DDS.
- ▶ External ARB clock input for synchronism with external signals.
- ▶ "System clock" architecture for reduced inter-channel skew.
- ▶ Auxiliary sinewave output (3rd or 5th output) on TGA12102/4.
- ▶ RS-232 and GPIB (IEEE-488.2) and USB interfaces.

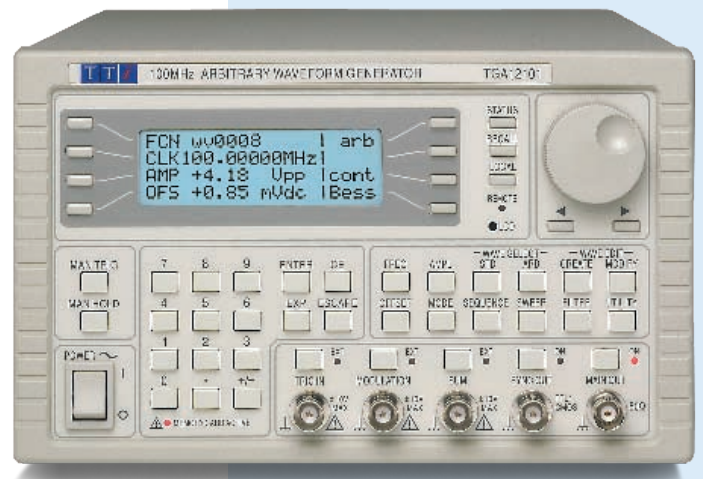

## Digital Function Generators

Digital function generators can be divided into three broad categories:

1. DDS\* Function Generators without Arbitrary - these perform a similar function to an analog function generator, but with the advantages of DDS based stability, resolution, and sinewave purity. The TG2000 falls into this category.

2. DDS Function/Arbitrary Generators - these have the ability to produce arbitrary waveforms in addition to standard waveforms, but within the limitation imposed by using a DDS system. The TG1010A falls into this category.

3. Universal Arbitrary Waveform Generators - these combine a DDS function generator with a variable-clock\* arbitrary generator. Typically these generators incorporate more sophisticated systems for the production of arbitrary waveforms. The TGA1240 and TGA12100 series (see page 13) fall into this category. The TG4001 also has a similar architecture.

\* For an explanation of DDS (direct digital synthesis) and of DDS and variable-clock architectures for generators - go to our web site:

[www.tti-test.com/go/arb](http://www.tti-test.com/go/arb)

for more complete information:  
[www.tti-test.com/generator](http://www.tti-test.com/generator)

Digital Function and Function/Arbitrary Generators - comparison table (see also TGA series - page 12)			
	TG2000	TG1010A	TG4001
Maximum Frequency (sine)	20MHz	10MHz	40MHz
Frequency Resolution (sine)	6 digits or 1mHz	7 digits or 0.1mHz	10 digits or 0.1mHz
Minimum Frequency	0.001Hz	0.0001Hz	0.0001Hz
Waveform Generation System	DDS	DDS	DDS **
Multi-Generator Phase Lock	No	Yes	Yes
Frequency Accuracy	Better than $\pm 10$ ppm		
Waveform Functions	Sine, Square, Triangle, +ve/-ve Pulse	Sine, Square, Triangle, +ve/-ve Pulse, +ve/-ve Ramp, Multi-level square, sinex/x	Sine, Square, Triangle, +ve/-ve Pulse, +ve/-ve Ramp, Pulse train, cosine, haversine, havercosine
Variable Symmetry Range	20% to 80% square/pulse	1% - 99% sine/triangle/ramp 20% to 80% square/pulse	N/A##
Variable Start/Stop Phase	No	1 degree resolution	0.1 degree resolution
Arbitrary Waveforms (Size)	No	Yes - 1K words	Yes - 8 to 64K words
Arbitrary Waveform Clock	-	27.48MHz (DDS)	0.1Hz to 100MHz
ARB Waveform PC Software	No	No	Waveform Manager Plus
Frequency Sweep (Range)	0.2Hz to 20MHz	0.1mHz to 10MHz	1mHz to 40MHz
Frequency Sweep (Rate/Mode)	50ms to 999s, lin or log	10ms to 999s, lin or log	1ms to 999s, lin or log
Internal/External AM	No	Yes/Yes	No/Yes
Internal Trigger Generator	0.001Hz to 5kHz	0.005Hz to 50kHz	0.005 Hz to 100kHz
Triggered Burst	No	1 to 1023 cycles	1 to 1048575 cycles
Gated Mode	Yes	Yes	Yes
Tone Switching/FSK Modes	Tone/FSK	FSK	Tone/FSK
Amplitude Range (pk-pk EMF)	5mV - 20V from 50/600 $\Omega$	5mV - 20V from 50/600 $\Omega$	5mV - 20V from 50 $\Omega$
DC Offset Range	$\pm 10$ V EMF	$\pm 10$ V EMF	$\pm 10$ V EMF
Sinewave Purity	Typically 0.1% to 20kHz <-40dBc at 20MHz	<0.3% to 500kHz, typically <-40dBc at 10MHz	<0.15% to 100kHz, typically <-35dBc at 40MHz
Output Flatness	$\pm 0.2$ dB to 500kHz; $\pm 1$ dB to 20MHz	$\pm 0.2$ dB to 200kHz; $\pm 1$ dB to 5MHz; $\pm 2.5$ dB to 10MHz	$\pm 0.2$ dB to 1MHz; $\pm 0.4$ dB to 40MHz
Auxiliary Output	Multi-function output for Waveform Sync, Trigger Out, Sweep Sync., Marker (not TG2000)		
Display	4 line backlit dot-matrix LCD		
Digital Interfaces	RS232/USB	RS232 (GPIB option)	RS232/USB (GPIB option)

Power: 230V or 115V AC nominal 50/60Hz, adjustable internally. Size & weight: TG2000: 260 x 88 x 235 mm (WxHxD) 2.0 kg (4.4lb). TG1010A and TG4001 are 3U half-rack: 212 x 130 x 335 mm (WxHxD). 4.1 kg (9 lb).

Notes: \*\* TG4001 uses DDS for function generator mode and variable-clock for arbitrary waveforms.  
## TG4001 has no waveform symmetry - asymmetric waveforms should be created as arbitrary waveforms.

## TG2000

- ▶ 20MHz DDS function generator
- ▶ High stability and resolution
- ▶ USB and RS232 interfaces

Further details are provided in the comparison table opposite. Full details are available on the web site.

The TG2000 is a high performance DDS based function generator covering the range 1mHz to 20MHz.

It is ideal for engineers who require a high stability and high resolution function generator, but who do not require arbitrary waveforms.

The TG2000 offers numeric or spin-wheel setting of all parameters and has a four line full-information display.

- ▶ 0.001Hz to 20MHz frequency range
- ▶ 6 digits or 1mHz resolution
- ▶ 1ppm stability and 10ppm one year accuracy
- ▶ Low distortion, high spectral purity sine waves
- ▶ Internal phase continuous sweep, lin or log
- ▶ AM, FSK, gated and tone switching modes
- ▶ 5mV to 20V pk-pk from 50 $\Omega$  or 600 $\Omega$
- ▶ Storage for multiple instrument set-ups
- ▶ USB and RS232 Interfaces



Unlike some other lower cost DDS based function generators, the TG2000 provides digital control of all parameters and functions.

This allows for complete control via the digital bus, and for the complete instrument status to be stored in the set-up memories.

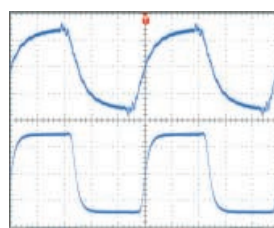

### Waveform Quality

Ultimately what matters in a function generator is the quality of the output signal. The TG2000 maintains the TTI reputation for high signal quality at all frequencies and all levels.

The waveform capture opposite shows just how much difference that can make. The 'scope display opposite was captured from two 5MHz square wave signals each at 60mV pk-pk level into 50  $\Omega$ .

The upper waveform is from a widely available competitive DDS generator. The lower waveform is from a TG2000.

The TG1010A is a high performance 10MHz DDS function generator with extensive modulations and the added benefit of basic arbitrary waveform capabilities.

It can produce frequencies down to 0.0001 Hz and has a built-in trigger generator. Triggered bursts with variable start-stop phase is available for all waveforms.

Wide range phase-continuous sweep is available at rates from 10ms to 15 minutes. Amplitude modulation is provided for all waveforms and an internal AM source is incorporated. The frequency agility of the DDS system is used to provide FSK and Frequency Hop facilities.

Arbitrary waveforms can be loaded via the digital interfaces and then used in a similar way to the standard waveforms. In addition, the TG1010A offers numerous "complex" waveforms pre-defined in ROM. These include commonly used wave-shapes such as sine x/x, decaying sinewave, exponential rise and fall etc.

- ▶ 0.1mHz to 10MHz frequency range, 7 digit resolution.
- ▶ Eight standard waveforms, plus multiple "complex" waveforms, true arbitrary waveforms and noise.
- ▶ Powerful modulation modes including Sweep, AM, Gating, Trigger/Burst, FSK and Hop.
- ▶ Variable symmetry, variable start/stop phase.
- ▶ 20V pk-pk output from 50Ω or 600Ω (switchable).
- ▶ Storage for five Arbitrary waveforms (1024 x 10-bits).
- ▶ Fully programmable via RS-232 or optional GPIB interfaces

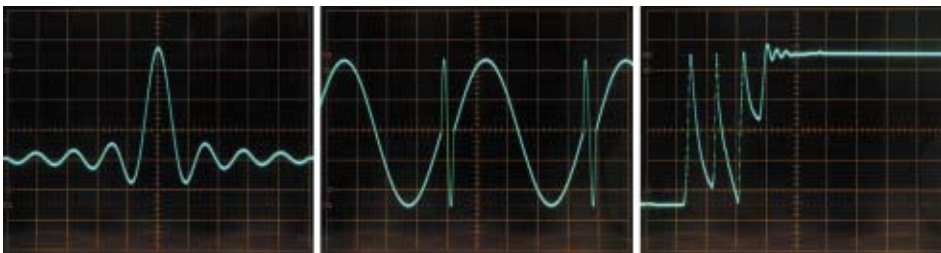

Pre-programmed 'complex' waveform    Frequency shifting on alternate cycles    Arbitrary waveform - contact bounce

Further details are provided in the comparison table opposite. Full details are available on the web site.

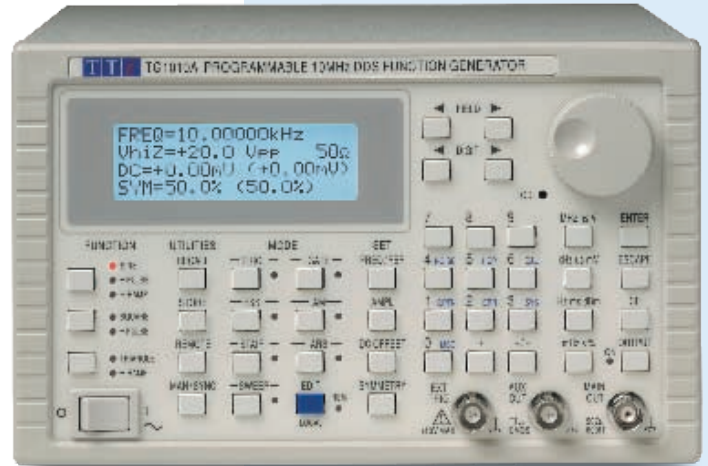

## TG1010A

- ▶ 10MHz DDS function generator
- ▶ Arbitrary waveform capability
- ▶ Wide range of modulations
- ▶ RS-232 and optional GPIB

The TG4001 provides high purity sine waves at up to 40MHz and square waves at up to 50MHz. No other DDS generator offers this performance at this price.

The output amplifier has a bandwidth approaching 100MHz ensuring that waveform quality is excellent right up to the frequency limits. Amplitude flatness is better than  $\pm 0.2$ dB to 1MHz and  $\pm 0.4$ db to 40MHz.

Low noise design ensures minimum waveform aberrations and provides high waveform quality even at minimum output amplitude.

In addition to its eleven 'standard' waveforms, the TG4001 can generate arbitrary waveforms of any length between 8 and 65,536 points at speeds of up to 100MS/s. Up to four arbitrary waveforms can be stored within the instrument.

As well as standard and arbitrary waveforms, The TG4001 can generate pulse trains. A pattern of up to 10 pulses can be quickly defined with each pulse having its own amplitude, width and delay.

- ▶ 0.1mHz to 40MHz range; 10 digits or 0.1mHz resolution.
- ▶ 11 standard waveforms including sine, square, triangle, haversine, ramp, pulse,  $\sin(x)/x$ .
- ▶ Pulse train generation for up to 10 pulses.
- ▶ Arbitrary waveforms of up to 64K points at up to 100MS/s.
- ▶ Modulations modes of sweep, burst, gated and tone switching; built-in trigger generator.
- ▶ 5mV to 20V pk-pk output from 50Ω ; plus multi function aux. out.
- ▶ Storage for nine instrument set-ups in non-volatile memory.
- ▶ Waveform Manager Plus for Windows software included.
- ▶ Programmable via RS-232 or USB interfaces; GPIB optional.

Further details are provided in the comparison table opposite. Full details are available on the web site.

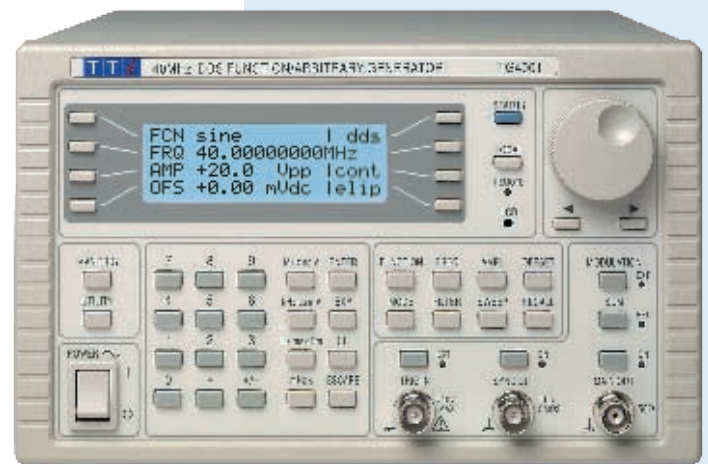

## TG4001

- ▶ 40MHz DDS function generator
- ▶ High speed arbitrary waveforms
- ▶ Pulse train generation
- ▶ RS-232, USB and optional GPIB

## Analog Function Generators

Function generators fall into two basic categories, analog and digital.

Analogue generators use a voltage controlled oscillator to generate a triangular waveform of variable frequency. Sinusoids and square waves are generated from this.

Digital generators use a digital to analog converter (DAC) to generate a wave shape from values stored in memory. Normally such generators only offer sine and square waves up to the maximum generator frequency. Triangle waves and other waveforms are limited to a much lower frequency.

Analogue generators offer several advantages:

1. They provide simple and instantaneous manual control of frequency and amplitude.
2. They do not have the high frequency limitations for non-sinusoidal waveforms such as triangles and ramps that digital generators do.
3. The starting price for an analog generator is considerably lower than for a digital generator.

The function generator is a particularly versatile instrument. It can generate a variety of precision wave shapes over a range of frequencies from mHz to MHz with a wide range of controlled amplitudes from a low-impedance source, and maintain constant amplitude as the frequency is varied.

Although digital function generators may offer more features, analog function generators have advantages that can make them more appropriate for certain applications.

Analog Function Generators - comparison table						
	TG210	TG315	TG320	TG330	TG550	TG120
Maximum Frequency	2MHz	3MHz		5MHz		20MHz
Minimum Frequency	0.02Hz	0.03Hz		0.005Hz		0.2Hz
Frequency Setting	Dial	Digital Readout via LCD				Dial
Waveform Functions	Sine, Square or Triangle all with variable symmetry (plus DC)					
Variable Symmetry Range	1:9 / 9:1 at frequency/10					1:6 / 6:1 *
Digital Frequency Lock	No	No		Yes		No
External Freq. Counter	No	No	Yes	Yes	Yes	No
External Sweep Input	1000:1	1000:1		1000:1		20:1
Internal Sweep Generator	No	No	Yes		Yes	No
Internal/External AM	No	No	Yes		Yes	No
Amplitude Range (pk-pk EMF)	20mV - 20V	2mV - 20V			10mV - 20V	
DC Offset Range	+/- 10V (reduced by attenuator setting)					
Amplitude/Offset Display	No	Digital Readout via LCD				No
Output Impedance	50Ω and 600Ω					50Ω
Auxiliary Output	TTL / CMOS square wave in phase with main output					

Power: 230V or 115V AC nominal 50/60Hz, adjustable internally. Size & weight: TG120: 220 x 82 x 230 mm (WxHxD). 1.5 kg (3.0 lb). TG210, TG315, TG320, TG330, TG550: 260 x 88 x 235 mm (WxHxD). 1.9 kg (4.2 lb).  
Notes: \* TG120 symmetry applies up to 500kHz.

### TG210

- ▶ Dial-set 2MHz function generator
- ▶ High waveform quality



The TG210 is a basic 2MHz function generator which offers very high waveform quality at all frequencies and levels. Frequency is set using a calibrated vernier knob.

The feature set includes variable symmetry at constant frequency and variable dc offset with centre detent.

Output impedances of 50Ω and 600Ω are supported via separate output sockets.

- ▶ 0.02Hz to 2MHz frequency range
- ▶ High waveform quality at all frequencies & levels
- ▶ 20mV to 20V pk-pk from 50Ω or 600Ω
- ▶ Sine, square and triangle waveforms plus dc
- ▶ 1000:1 frequency change on each range
- ▶ Variable symmetry control
- ▶ External sweep input

### TG120

- ▶ Dial-set function generator
- ▶ 20MHz frequency range



The TG120 uses a different waveform generation technique from that used in other TTI analog function generators.

By doing so it achieves a greatly extended maximum frequency point of 20MHz.

Although offering a slightly poorer overall specifications than other TTI generators, it represents excellent value for users who require a high frequency waveform source.

- ▶ 0.2Hz to 20MHz frequency range
- ▶ Sine, square and triangle waveforms plus dc
- ▶ 10mV to 20V pk-pk from 50Ω
- ▶ DC offset control with zero detent
- ▶ Variable symmetry control
- ▶ External sweep input
- ▶ Excellent price/performance ratio

The TG300 series are analog function generators with a digital display which provides simultaneous readout of frequency and level (amplitude pk-pk, amplitude rms or dc offset).

Two models include an external counter with 7 digit resolution (using the full width of the display) at up to 120MHz.

The top model includes a sweep generator and internal/external amplitude modulation.

- ▶ 0.03Hz to 3MHz frequency range
- ▶ Simultaneous display of frequency and amplitude
- ▶ External seven digit 120MHz counter (not TG315)
- ▶ High waveform quality at all frequencies & levels
- ▶ 2mV to 20V pk-pk from 50Ω or 600Ω
- ▶ Variable symmetry with constant frequency
- ▶ Auxiliary TTL/CMOS output
- ▶ 1000:1 freq. change by vernier or sweep voltage
- ▶ Precision internal lin/log sweep (TG330 only)
- ▶ Internal/external AM up to 100% (TG330 only)

*Further details are provided in the comparison table opposite. Full details are available on the web site.*

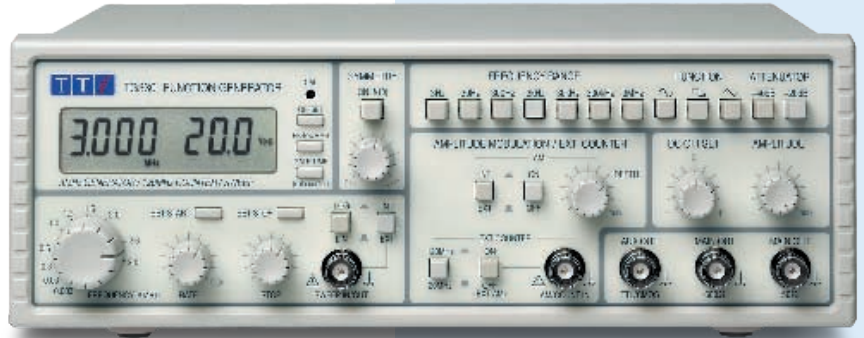

◀ TG320 in external frequency counter mode. The reciprocal counting measurement technique with dual gate times is fully auto-ranging giving up to seven digits of resolution over the full frequency range of 5Hz to 120MHz.



## TG300 series

- ▶ 3MHz function generator range
- ▶ Display of frequency and level
- ▶ 120MHz frequency counter
- ▶ Choice of three models

### Model range:

TG315 - basic dual-display function generator.

TG320 - as TG315 with external counter.

TG330 - as TG320 with sweep generator and amplitude modulation.

The TG550 is the most advanced analog function generator in the TTI range.

It includes a digital frequency locking system which, when enabled, continuously compares the output with a crystal reference.

The TG550 has a dual display to show both frequency and level (amplitude pk-pk, amplitude rms or dc offset).

It has an external counter with 7 digit resolution (using the full width of the display) at up to 20MHz.

It also includes a sweep generator with linear and logarithmic sweep capability, and internal/external amplitude modulation.

- ▶ 0.005Hz to 5MHz frequency range
- ▶ Built-in seven digit 20MHz frequency counter
- ▶ Digital frequency lock for exceptional stability
- ▶ Simultaneous display of frequency and voltage amplitude or offset
- ▶ Internal or external AM at up to 100%
- ▶ Precision internal lin/log sweep

*Further details are provided in the comparison table opposite. Full details are available on the web site.*



## TG550

- ▶ 5MHz function generator
- ▶ Display of frequency and level
- ▶ Digital frequency locking
- ▶ Built-in sweep generator

## Product Range

### Digital Multimeters - page 18

Bench-top multimeters with from 4¼ to 5½ digit resolution, all with true rms ac and digital control interfaces.

### Component Measurement - page 20

Precision LCR bridge, micro-ohm meter.

### I-Prober Current Probe - page 21

Innovative probe for applications that include non-contact measurement of currents in PCB tracks.

### Power Source Testing - page 22

Electronic DC Load for power supply and battery testing. Proving unit for volt-sticks.

### Frequency Measurement - page 23

Bench-top universal counter and handheld frequency meter.

### Power Analysis

See RF & EMC section (page 27)

## Precision measurement instruments

TTi has been designing and manufacturing precision measurement instruments for nearly thirty years.

Expertise in precision analog design has enabled the company to offer high performance products with advanced features at attractive prices.

TTi offers instruments for the precision measurement of all of the fundamental electronic parameters including voltage, current, resistance, capacitance, inductance, power and frequency.

The new I-Prober open field current probe will enable the measurement of current in situations where it was previously not possible.



## Digital Multimeters

### Bench-top DMMs versus hand-held

Low cost hand-held DMMs have replaced bench-top DMMs in many applications. Although the performance of these meters may be sufficient for some tasks, it is likely that most engineers will regularly encounter measurement problems that are beyond the capability of a hand-held unit.

### An instrument intended for serious use

A TTi bench-top DMM is a substantial instrument. It stays where you put it even with heavy test leads connected. The tilt stand ensures that the large display is always readable. The functions buttons are large and the front panel is clearly marked.

### Sensitivity, Resolution and Accuracy

Compare the performance of any TTi bench-top DMM with a good quality 4000 count hand-held DMM of 0.3% basic dcV accuracy.

Longer scale length, greater sensitivity and higher accuracy ensure that measurement uncertainty is a full order of magnitude better.

TTi bench-top DMMs maintain good accuracy on all functions including ac voltage, resistance and current. For most hand-helds, the accuracies for functions other than dc voltage are dramatically poorer.

### Wideband ac measurement and true RMS

Most hand-held DMMs have an ac frequency response specified to below 1kHz. All TTi bench-top DMMs provide excellent accuracy on all ranges throughout the audio band (40Hz to 20kHz) with a 3dB bandwidth extending well above this.

Most ac signals are not sinusoidal. However, most hand-held DMMs incorporate a mean sensing ac converter which only gives useful results on sinusoids, those that do have a True RMS converter often have insufficient bandwidth to cope with complex waveshapes. All TTi bench-top DMMs combine True RMS ac with sufficient bandwidth to ensure accurate results.

Digital Multimeters - Comparison Table			
	1604	1705 & 1705-GP	1906 & 1906-GP
Display Type	LED	Dual LCD	LED
Scale Length (Counts)	40,000	12,000	210,000
Dual Measurement	No	Yes	No
DC Voltage: Ranges	(5) 400mV to 1000V	(5) 120mV to 1000V	(5) 200mV to 1000V
Best Resolution	10µV	10µV	1µV
Basic Accuracy	0.08%	0.04%	0.012%
AC Voltage: Ranges	(5) 400mV to 750V	(5) 120mV to 750V	(5) 200mV to 750V
True RMS conversion	Yes	Yes	Yes
Frequency Response	0.08%	0.04%	0.012%
DC/AC Current: Ranges	(3) 4mA to 10A	(3) 1.2mA to 10A	(6) 200µA to 10A
Best Resolution	100nA	100nA	1nA
Resistance: Ranges	(6) 400Ω - 40MΩ	(7) 120Ω - 20MΩ	(6) 200Ω - 20MΩ
Best Resolution	10µΩ	10µΩ	1µΩ
Frequency	Yes	Yes	No
Capacitance	No	Yes	No
Smart Functions	3	12	9
Interfaces: RS-232	Yes *	Yes	Yes
GPIB (IEEE-488)	No	Yes (GP version)	Yes (GP version)
Power Source	AC Line	AC Line or Battery	AC Line

### PC and System connectivity

At some point most engineers are going to want to connect their DMM to their personal computer to provide automatic measurement control or importing of data into a computer programme. Unlike a hand-held DMM, all TTi bench-top DMMs include a fully isolated RS-232 interface.

For full system applications, the 1705-GP and 1906-GP also have a GPIB (IEEE-488) interface.

### Functions & features of real value

Hand-held DMMs may offer a few "smart" features but these are rarely well enough implemented to be of real use.

TTi bench-top DMMs offer features which are of real use and not just "gimmicks". Features such as dual Measurement & display, precision frequency measurement, dBm, data logging, power and VA, to mention just a few.

\* RS232 interface on 1604 is only for use with the optional PC-1604 control and data logging software.

Full technical details for all three multimeters is available on the web site.

Function	Ranges	Best Resolution	Best Accuracy
DC V	(5) 400mV - 1000V	10 $\mu$ V	0.08% $\pm$ 4 digits
AC V	(5) 400mV - 750V	100 $\mu$ V	0.5% $\pm$ 4 digits
Resistance	(6) 400 $\Omega$ - 40M $\Omega$	10 $\mu$ $\Omega$	0.1% $\pm$ 4 digits
DC I	(3) 4mA - 10A	0.1 $\mu$ A	0.1% $\pm$ 4 digits
AC I	(3) 1mA - 10A	1 $\mu$ A	0.1% $\pm$ 4 digits
Frequency	(2) 4kHz to 40kHz	0.1Hz	0.01% $\pm$ 1 digit

Further measurement functions: Continuity, Diode Test.  
 Smart functions: Null (Relative), Hold, T-Hold, Min/Max.  
 Interface: opto-isolated bi-directional RS-232 interface. 9600 baud.  
 Power: 230V or 115V AC nominal 50/60Hz, adjustable internally.  
 Size & weight: 260 x 88 x 235 mm (WxHxD). 2.0 kg (4.4 lb)

- ▶ 40,000 counts, auto or manual ranging
- ▶ Accuracy and resolution, 0.08%, 10 $\mu$ V, 10m $\Omega$
- ▶ Large and bright LED display (14mm/0.56")
- ▶ True RMS ac functions, wide ac bandwidth
- ▶ Relative, T-Hold and Min-Max functions included
- ▶ Optional PC control and logging software

The 1604 is a high quality 40,000 count bench-top multimeter with a wide range of features.

It offers automatic or manual ranging, high resolution (10 $\mu$ V, 10m $\Omega$ ) together with current measurement up to 10A.

## 1604 DMM

- ▶ 4 $\frac{3}{4}$  digit bench-top multimeter
- ▶ 0.08% basic dc-v accuracy
- ▶ True RMS ac functions
- ▶ Isolated RS-232 interface\*



Function	Ranges	Best Resolution	Best Accuracy
DC V	(5) 120mV - 1000V	10 $\mu$ V	0.04% $\pm$ 2 digits
AC V	(5) 120mV - 750V	100 $\mu$ V	0.2% $\pm$ 20 digits
Resistance	(6) 120 $\Omega$ - 20M $\Omega$	10 $\mu$ $\Omega$	0.08% $\pm$ 2 digits
DC I	(3) 1mA - 10A	0.1 $\mu$ A	0.1% $\pm$ 3 digits
AC I	(3) 1mA - 10A	0.1 $\mu$ A	0.3% $\pm$ 20 digits
Capacitance	(5) 10nF to 100nF	10pF	2% $\pm$ 5 digit

Further measurement functions: Continuity, Diode Test, Frequency  
 Smart functions: Null (Relative), Hold, T-Hold, Min/Max, dB, Ax+B, % deviation, VA.  
 Logger: 100 readings. Interfaces: RS-232 standard. GPIB (IEEE-488) optional.  
 Power: 230V or 115V AC 50/60Hz, or 6 x C cells disposable or rechargeable.  
 Size & weight: 260 x 88 x 235 mm (WxHxD). 2.0 kg (4.4 lb)

- ▶ Dual 12,000 count LCD, auto/manual ranging
- ▶ Accuracy and resolution: 0.04%, 10 $\mu$ V, 10m $\Omega$
- ▶ Dual displays & 'dual measurement' technology
- ▶ True RMS ac functions, Frequency, Capacitance
- ▶ Wide range of computing functions e.g. Ax + B
- ▶ Model with GPIB (IEEE-488) interface available
- ▶ Mains and battery operation as standard

The 1705 is a precision 4 $\frac{1}{4}$  digit bench multimeter incorporating dual displays and dual measurement technology.

The dual displays can be used either to display one measurement in two units (e.g. mV and dB) or to measure two parameters simultaneously (e.g. dc-V and ac-V).

## 1705 DMM

- ▶ Dual measurement multimeter
- ▶ 0.04% basic dc-v accuracy
- ▶ Built-in data logger
- ▶ Isolated RS-232 or GPIB
- ▶ AC line or battery operation



Function	Ranges	Best Resolution	Best Accuracy
DC V	(6) 210mV - 1000V	1 $\mu$ V	0.012% $\pm$ 3 digits
AC V	(6) 400mV - 750V	10 $\mu$ V	0.2% $\pm$ 25 digits
Resistance	(6) 400 $\Omega$ - 40M $\Omega$	1 $\mu$ $\Omega$	0.019% $\pm$ 3 digits
DC I	(3) 4mA - 10A	1nA	0.08% $\pm$ 12 digits
AC I	(3) 1mA - 10A	10nA	0.37% $\pm$ 25 digits

Further measurement functions: Continuity, Diode Test.  
 Smart functions: Null (Relative), Hold, T-Hold, Min/Max, Ax + B, % deviation, dB, Digital filtering. Logger: 100 readings, manual or automatic.  
 Interfaces: RS-232 standard. GPIB (IEEE-488) optional.  
 Power: 230V or 115V AC nominal 50/60Hz, adjustable internally.  
 Size & weight: 260 x 88 x 235 mm (WxHxD). 2.2 kg (4.8 lb)

- ▶ 210,000 counts, auto or manual ranging
- ▶ Accuracy and resolution: 0.012%, 1 $\mu$ V, 1m $\Omega$
- ▶ Four terminal resistance measurement
- ▶ True RMS ac functions, wide ac bandwidth
- ▶ Wide range of computing functions included
- ▶ Automatic data logging functions include
- ▶ Digital filtering for improved noise rejection
- ▶ Model with GPIB (IEEE-488) interface available

The 1906 is a precision bench-top multimeter offering both high resolution and high accuracy.

The precision is matched by a four terminal ohms measurement.

It's wide range of facilities include many 'smart' calculation functions and a data logger.

## 1906 DMM

- ▶ 5 $\frac{1}{2}$  digit bench-top multimeter
- ▶ 0.012% basic dc-v accuracy
- ▶ 1 $\mu$ V, 1nA, 1m $\Omega$  resolution
- ▶ True RMS ac functions
- ▶ Isolated RS-232 or GPIB



## LCR400 LCR bridge

- ▶ 0.1% basic accuracy
- ▶ Built-in component fixture
- ▶ Built-in limits comparator
- ▶ RS-232 interface

Note: Full technical details are available on the web site.



The LCR400 is a high performance LCR meter that offers an alternative to low-cost handheld units or expensive system units.

Dual displays, automatic component recognition and auto-ranging make it easy to use, while its built-in test fixture and limits comparator make it suitable for applications within the laboratory, production or inspection areas.

- ▶ 0.1% basic measurement accuracy
- ▶ Three test frequencies of 100Hz, 1kHz and 10kHz
- ▶ Automatic component recognition
- ▶ Built-in 4 terminal component fixture
- ▶ Dual 5 digit high brightness displays
- ▶ Limits comparator with multiple pass and fail bins
- ▶ RS-232 interface for PC connectivity
- ▶ Optional SMD tweezers, Kelvin Clip leads, Windows logging software

Note: accessories not to same scale as LCR400



Range and resolution limits:  
Resistance: 0.1mΩ to 990MΩ  
Inductance: 0.001μH to 9900H  
Capacitance: 0.001pF to 99000μF

## BS407 low Ohmmeter

- ▶ 0.1% basic accuracy
- ▶ 1μΩ to 20kΩ range
- ▶ Kelvin clip connection leads
- ▶ Rechargeable battery operation

Note: Full technical details are available on the web site.



- ▶ High basic accuracy of 0.1%
- ▶ Wide measurement range of 1μΩ to 20kΩ
- ▶ Current reversal switch for detecting thermal emf
- ▶ Current diversion switch for easy zero setting
- ▶ Four terminal measurement using Kelvin clip leads
- ▶ Battery operation with built-in charger
- ▶ Switchable 20mV clamp for 'dry circuit' testing

The BS407 is fully optimised for the task of accurate measurement of low resistances with a best resolution of 1μΩ.

It uses a Direct Current technique to measure true resistance, rather than the resistive component of impedance which is shown by AC excited LCR bridges. The test current for each range has been chosen to minimise heating of the sample under test while being sufficient to minimise the effects of thermal emf and noise.

This gives much greater accuracy at low resistances than can be obtained from the very low test currents used by general purpose high resolution multimeters.



## New Product

The I-Prober 520 is available in late 2009

for more information on this innovative product, go to the TTI web site: [tti-test.com/go/iprober](http://tti-test.com/go/iprober)

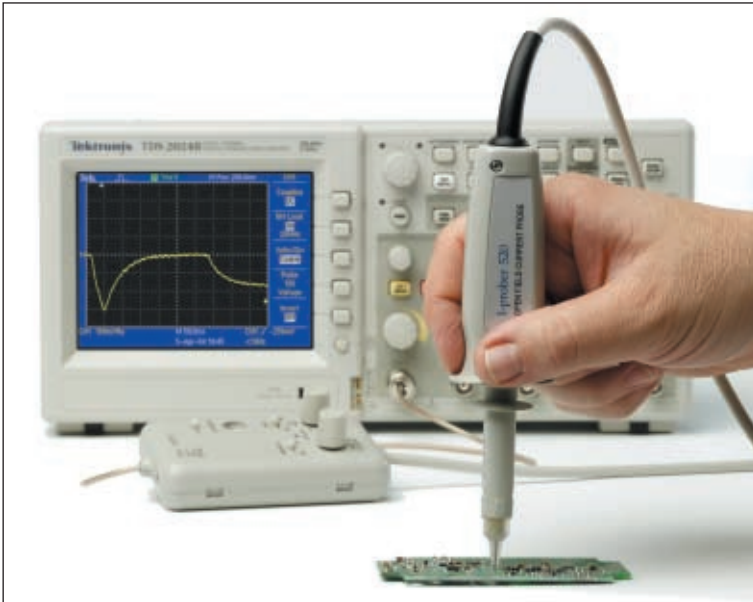

- ▶ Current measurement from non-contact probing of conductor
- ▶ Wide dynamic range of 5mA to 20A peak to peak
- ▶ Wide bandwidth of DC to 5MHz
- ▶ Low noise equivalent to <math><5\text{mA rms}</math>
- ▶ Designed to meet safety requirements to 600V Cat II
- ▶ Suitable for connection to any oscilloscope
- ▶ High accuracy general purpose H-field probe
- ▶ Convertible into standard 'closed magnetic circuit' current probe

The I-Prober 520 is supplied with a clip-on toroid assembly which converts it into a closed magnetic circuit probe for measuring current in a wire.

The toroid is open until the probe is attached, allowing insertion of the wire without disconnection.

The wide bandwidth, dynamic range and low noise of the probe are retained.



## I-Prober 520

- ▶ Current measurement by simple non-contact probing of PCB track
- ▶ DC to 5MHz bandwidth
- ▶ 5mA to 20A dynamic range
- ▶ Low noise figure



The I-Prober 520 open field current probe is unlike any other current measurement device available.

Calibrated measurement of current normally requires the current to be passed through a closed magnetic loop. Typically this is done using some form of split clamp device. Whereas this is suitable for individual wires, it is of no use for measuring current in PCB tracks.

The I-Prober 520 is a compact hand-held probe which is used with an oscilloscope. By placing the insulated tip of the probe onto a PCB track, the current flowing in the track can be observed and measured.

### LD300 dc load

- ▶ 300 watt dc electronic load
- ▶ Up to 80 volts or 80 amps
- ▶ CI, CR, CV and CP modes
- ▶ Built-in transient generator

*Note: Full technical details are available on the web site.*

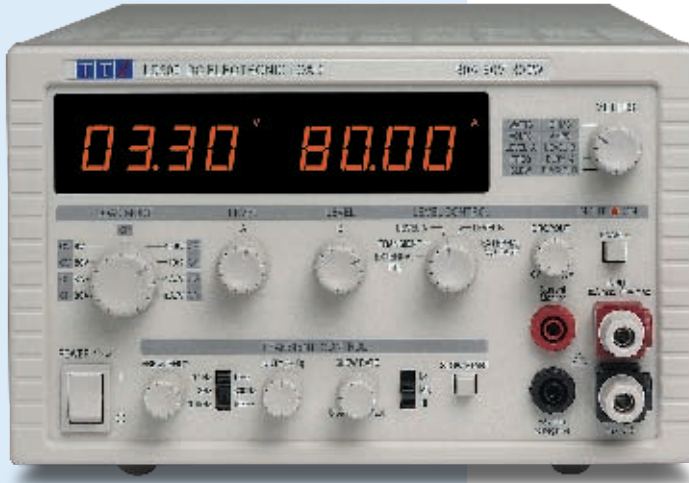

- ▶ Versatile solution for testing dc power sources
- ▶ Constant current, constant resistance, constant conductance, constant voltage and constant power modes
- ▶ Wide voltage and current range, 0 to 80 volts and 0 to 80 amps.
- ▶ 300 watts continuous dissipation at 40°C
- ▶ Low minimum operating voltage of <1V at 40A
- ▶ Ten turn controls for level setting
- ▶ Built-in transient generator with variable slew
- ▶ Current monitor output for waveform viewing
- ▶ Variable drop-out voltage for battery testing
- ▶ Analog remote control capability

The LD300 is an inexpensive electronic load which is suitable for testing and characterising a wide variety of dc power sources.

It can be used to investigate the behaviour of many different types of power source such as batteries, solar cells, fuel cells or wind generators, as well as electronic power supply units.

Its wide voltage/current range, multiple operating modes and built-in transient generator give it the versatility to offer test solutions from the design laboratory through to the component

### P240 proving unit

- ▶ Essential equipment for safety compliance
- ▶ Long-life battery operation
- ▶ Belt-clip mountable



The P240 is a hand-held battery powered proving unit that provides a nominal 240V dc, 2mA source intended for proving the integrity of neon type test voltage indicators.

For safety compliance, voltage indicators should be checked for correct operation from this known voltage source before and after every use.

Testing is performed by inserting the test probes of the neon tester into two recessed "touch proof" terminals on the proving unit. Insertion of the probes automatically turns the proving unit on thus eliminating the need for an on-off switch.

- ▶ 0.001Hz to 3000MHz frequency range
- ▶ Frequency, period, pulse width and totalise modes
- ▶ Reciprocal counting measurements
- ▶ High impedance measurement up to 125 MHz
- ▶ Low pass filter, attenuator and trigger level control
- ▶ AC or DC coupling, 1M/50Ω selection, polarity invert
- ▶ Large 10 digit LCD display with annunciators
- ▶ Operation from built-in rechargeable batteries
- ▶ Low power consumption
- ▶ Remote control and readback via USB
- ▶ TCXO timebase

The TF930 is a high quality bench/portable 3GHz universal frequency counter which offers period measurement, frequency ratio, pulse width and event counting.

It uses an advanced reciprocal frequency counting technique to achieve high resolution at all frequencies. A dc coupled input enables VLF measurements to be made (down to 1mHz). The timebase uses a high quality TCXO crystal with a very low ageing rate. An external reference can also be used.

The large 10 digit LCD has a full set of annunciators. Measurement times can be set between 0.3 seconds and 10 seconds.

Pulse width measurements can be made from rising to falling or falling to rising edge with adjustable thresholds. A variable attenuator is incorporated the input impedance is switchable between 1MΩ and 50Ω.

The instrument operates from internal rechargeable NiMH batteries which give typically 24 hours operating life. The universal AC charger supplied will recharge the batteries in less than 4 hours and can be used for continuous AC operation.

Full remote control and read-back is provided via a USB interface.

*Note: Full technical details are available on the web site.*

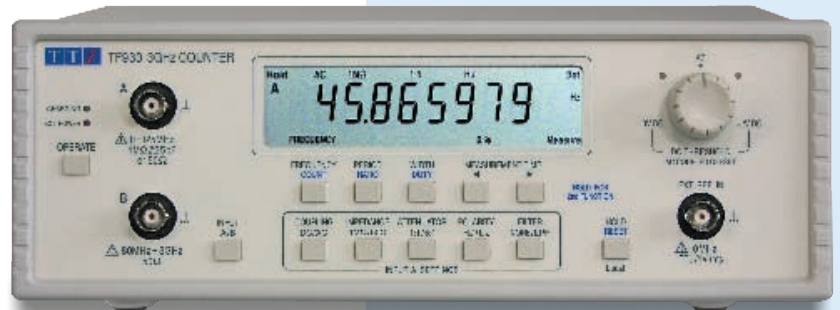

## TF930

- ▶ DC to 3GHz frequency range
- ▶ Frequency, period, pulse width, ratio and event counter modes
- ▶ Rechargeable batteries
- ▶ USB interface included

- ▶ 3Hz to 3000MHz frequency range
- ▶ Frequency and period measurement
- ▶ High sensitivity at all frequencies
- ▶ Switchable low pass filter
- ▶ Continuous reciprocal counting measurement
- ▶ 0.001mHz low frequency resolution
- ▶ Push-to-measure function with auto power-down
- ▶ Large 8.5 digit display with full range of annunciators

The PFM3000 is the latest handheld frequency counter from TTI offering measurement up to 3GHz.

It provides high impedance measurement up to 100MHz and 50Ω measurement up to 3000MHz, with excellent sensitivity across all frequencies.

It can measure both frequency and period and uses a continuous reciprocal frequency counting technique which gives high resolution and accuracy at all frequencies.

Despite its wide frequency range the PFM3000 has a low power consumption enabling it to operate for many hours from a disposable battery.

A push-to-measure capability is provided to extend battery life when continuous signal monitoring is not required.

*Note: Full technical details are available on the web site.*

## PFM3000

- ▶ 3Hz to 3GHz frequency range
- ▶ Frequency or period display
- ▶ Continuous reciprocal measurement
- ▶ Handheld format
- ▶ Long battery life



## Product Range

### RF Power Meters - page 24

TTi-Satori ST series USB linked RF and microwave power meters up to 26.5GHz.

### Spectrum Analyzers - page 25

PSA-T series low-cost handheld spectrum analyzers, 1.3GHz and 2.7GHz.

### Signal Generators - page 26

Synthesised RF signal sources offering exceptional value for money, 1GHz and 2GHz.

### Harmonics & Flicker Measurement - page 27

Compliance quality power and harmonics analyzer and source for measurements to EN61000-3-2 and EN61000-3-3.

### Frequency Measurement

See Precision Measurement section (page 23).

## RF and EMC Test Equipment

### RF Test

The rapid growth in the use of wireless communications and the inclusion of RF elements into many electronic designs has increased the need for RF test equipment.

The high cost of products from the major producers in this area has led TTI to develop lower cost alternatives for the essential RF tools such as signal generators and spectrum analyzers.

RF products from TTI are designed to offer the essential elements required by engineers at significantly lower costs.

### EMC Test

Most countries have now implemented legislation requiring products to comply with standards for radiated and conducted emissions.

TTi has produced equipment capable of compliance quality measurements, enabling users to self-certify for current harmonics and flicker.

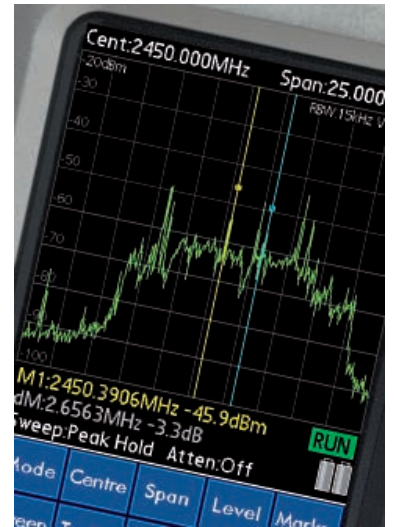

## Satori ST Series

- ▶ USB linked power meters
- ▶ 12.4GHz, 18.5GHz or 26.5GHz
- ▶ -50 dBm to +20 dBm range
- ▶ Very low power consumption



The TTI-Satori ST series power sensors are complete miniature RF & Microwave power meters. They contain a CPU which controls the sensor, processes the measurement results and operates the interface.

All measurement data and settings are transmitted via a USB interface to and from a PC. The supplied virtual power meter software for Windows creates a classic microwave power meter.

*Note: Full technical details are available on the web site.*

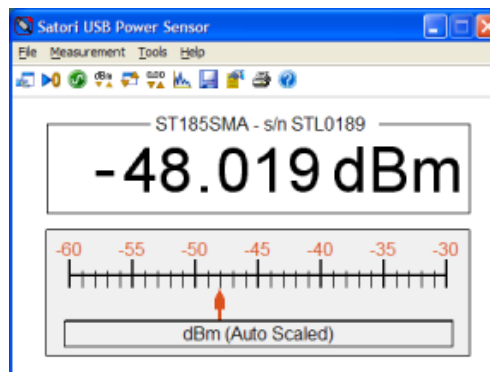

- ▶ Three models 12.4GHz, 18.5GHz or 26.5GHz
- ▶ Measurement down to 10MHz
- ▶ Measurement range from -50 dBm to +20 dBm
- ▶ Replacement solution for conventional power meter and sensor combination
- ▶ Simple USB connection to laptop or PC
- ▶ Use multiple sensors on one computer
- ▶ Very low power consumption (50mA)
- ▶ No reference calibrator required
- ▶ Lightweight and easy to use
- ▶ Robust construction with excellent reliability
- ▶ Convenient for production test and field service

Model	Frequency Range
ST124SMA	10MHz to 12.4GHz
ST185SMA	10MHz to 18.5GHz
ST265SMA	10MHz to 26.5GHz

Size and weight:  
34mm high x 43mm wide x 125mm long; 83 grams

The power meter is controlled by the TTI-Satori software loaded on a Windows PC. This is a virtual power meter with basic measurement functions for the PC workstation.

A software toolkit is supplied to control the power sensors via the PC. It includes a DLL (dynamic link library) for individualized use of the entire sensor functionality with Windows and the user interface.

Model	Frequency Range
PSA1301T	150 kHz to 1300 MHz
PSA2701T	1 MHz to 2700 MHz
Size and weight: 170mm high x 97mm wide x 47mm deep 495 grams total	

The PSA1301T and PSA2701T are low-cost, highly portable RF spectrum analyzers.

They incorporate the features most needed in a portable spectrum analyzer, together with many additional functions provided within the handheld computer.

- ▶ 150kHz to 1300MHz frequency range (PSA1301T)
- ▶ 1MHz to 2700MHz frequency range (PSA2701T)
- ▶ Resolution bandwidths of 280kHz or 15kHz (PSA1301T)
- ▶ 1MHz, 280kHz or 15kHz (PSA2701T)
- ▶ High resolution (480 x 320 pixel) TFT colour screen
- ▶ -96dBm typical noise floor at -20dBm reference level
- ▶ Measurement in dBm or dB $\mu$ V
- ▶ Fully adjustable centre frequency and span in 1kHz steps
- ▶ Choice of centre/span or start/stop setting
- ▶ Zero span mode with AM and FM audio demodulation
- ▶ Sweep modes of normal, single, peak hold and average
- ▶ Reference waveforms displayed in contrasting colour
- ▶ Twin markers with readout of absolute & difference values
- ▶ Smart marker movement with selectable peak tracking
- ▶ Amplitude limit lines with editor and store/recall
- ▶ Unlimited storage for waveforms, set-ups and screens
- ▶ Data transfer to PC for analysis, documentation & printing
- ▶ More than 4 hours continuous operation from a charge
- ▶ Smaller and lighter than any other spectrum analyzer (weight less than 0.5kg)

#### plus:

- ▶ Handheld computer based facilities including word processing, spreadsheets, appointments, picture/video viewing, MP3, Web and Email via Bluetooth and WiFi
- ▶ Large range of third party programs available including many for engineering, science and mathematics



## PSA-T series

- ▶ True handheld spectrum analyzers
- ▶ 1.3 GHz and 2.7 GHz models
- ▶ Half VGA colour screen
- ▶ Built-in handheld computer



to see a full product  
information tour:  
[www.tti-test.com/psa](http://www.tti-test.com/psa)

The small size, low weight and long battery life of the PSA-T Series make it the ideal tool for RF field measurements.

However, its surprisingly low cost provides every engineer with the potential to own a spectrum analyzer, whether they work in the RF field or not. The PSA-T Series will find applications within development, servicing and production as well as field use.

## TGR1040

- ▶ 1 GHz signal generator
- ▶ -127dBm to +7dBm
- ▶ RS-232, optional GPIB
- ▶ Low cost

*Note: Full technical details are available on the web site.*



- ▶ 10MHz to 1000MHz frequency range
- ▶ Accuracy better than 1ppm over 15°C to 30°C
- ▶ Ageing better than 1 ppm over one year
- ▶ Low phase noise and low leakage
- ▶ -127dBm to +7dBm amplitude, 0.1dB steps
- ▶ Amplitude entry in dBm or  $\mu$ V / mV
- ▶ FM modulation, internal or external
- ▶ Four line back-lit dot matrix LCD display
- ▶ Keyboard and rotary encoder control
- ▶ Non-volatile storage for 9 generator set-ups
- ▶ Full remote control through RS232 or optional GPIB
- ▶ Significantly lower cost than other synthesized RF generators

The TGR1040 is the low cost solution for RF engineers who require a basic RF generator of high stability and wide amplitude range. It has good phase noise and low leakage and offers FM modulation, internal or external.

## TGR2050

- ▶ 2 GHz signal generator
- ▶ -127dBm to +7dBm
- ▶ AM, FM & phase modulation
- ▶ RS-232 and GPIB standard

*Note: Full technical details are available on the web site.*



- ▶ 150kHz to 2000MHz frequency range
- ▶ 10Hz frequency setability
- ▶ Locking to external frequency standard
- ▶ Accuracy better than 1ppm over 15°C to 30°C
- ▶ Ageing better than 1 ppm over one year
- ▶ Low phase noise and low leakage
- ▶ -127dBm to +7dBm amplitude, 0.1dB steps
- ▶ Amplitude entry in dBm or  $\mu$ V / mV
- ▶ FM, Phase and AM modulation, internal or external
- ▶ Keyboard and rotary encoder control
- ▶ Non-volatile storage for 9 generator set-ups
- ▶ Full remote control through RS232 and GPIB
- ▶ Exceptional price/performance ratio

The TGR2050 offers a wide frequency range with a setability of 10Hz. It has 1ppm internal stability and can be locked to an external standard.

Modulation facilities of FM, Phase and AM are included.

## HA1600A

- ▶ Compliance quality current harmonics measurements to EN61000-3-2 when using compliant source (such as AC1000A)
- ▶ Tabular and histogram display of harmonics
- ▶ Continuous analysis with real-time graphical update
- ▶ Compliance quality fluctuations and flicker measurements to EN61000-3-3
- ▶ Full power analyzer measuring Watts, VA, Vrms, Vpk, Arms, Apk, A-inrush, CF, THD, PF, Hz
- ▶ Real-time voltage and current waveform displays
- ▶ Wide range of national power connectors available
- ▶ Parallel printer port plus RS232 and USB interfaces
- ▶ Windows PC control and documentation software supplied

- ▶ Compliance measurements to EN61000-3-2 & EN61000-3-3
- ▶ Tabular and histogram display of harmonics
- ▶ Continuous analysis with real-time graphical update
- ▶ Full power analyzer features
- ▶ PC software supplied

Note: Full technical details are available on the web site.

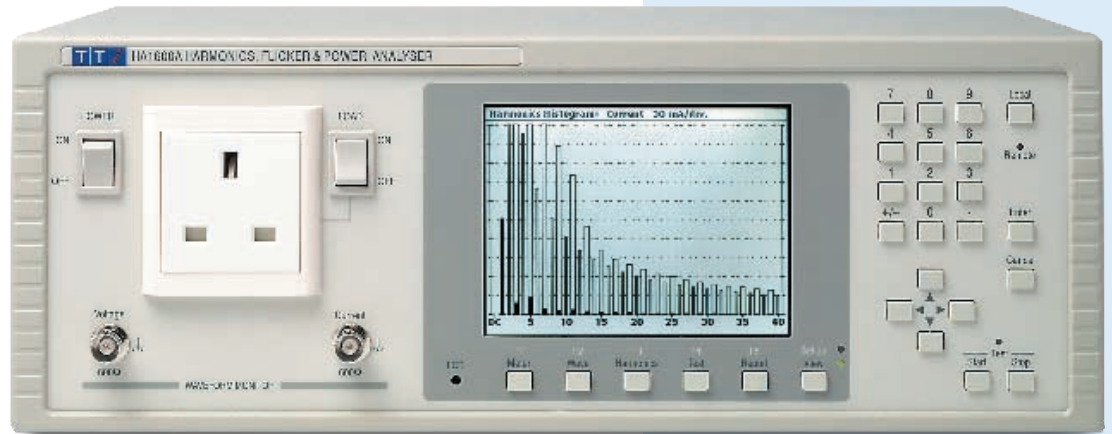

Power Meter			
Supply Voltage			
229.8 V <sub>rms</sub>	0.1% THD	Frequency	50.04 Hz
325.1 V <sub>pk</sub>	at 89.4°	Crest Factor	1.414
Lead Power			
47.64 W	64.03 VA	Power factor	0.744
Lead Current			
278.6 mA <sub>rms</sub>	49.9% THD	90.7% under Class B mask	
586.0 mA <sub>pk</sub>	Phase 12.5°	Crest Factor	2.103
Harmonic Summary			
Lead detected Class A by waveform.			
Lead passes Harmonic levels.			
Supply meets IEC requirements.			

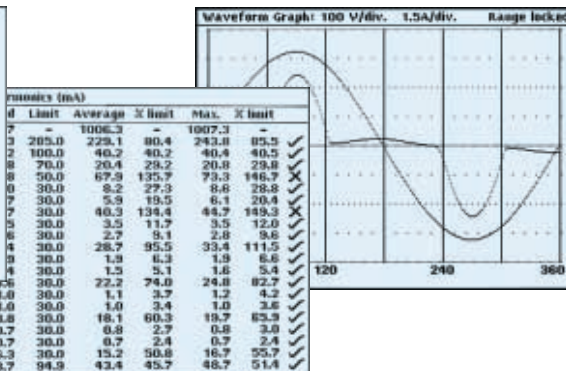

The HA1600A is a fast, easy to use power and harmonics analyzer with a large and high resolution graphical display, capable of continuous real-time analysis.

The HA1600A is intended primarily as a dedicated harmonics and flicker analyzer for compliance quality measurements, but it can also be used as a general purpose power analyzer.

The unit is available with range of power connectors to suit different national standards.

A printer interface is included along with RS-232 and USB interfaces for PC connectivity.

It is suitable for both the product development environment, and for production line test verification.

## AC1000A

The AC1000A is an innovative, low cost, pure power source designed specifically for use with a harmonics analyser such as the TTI HA1600A. It permits compliance quality measurements to EN61000-3-2 in situations where the quality of the AC supply is poor or variable. The AC1000A has a power rating of 1000 watts at 230 volts. Maximum continuous rms current is 4.4A with a peak current capability of 10A.

Note: Full technical details are available on the web site.

- ▶ 1 kW low-distortion source
- ▶ Suitable for EN61000-3-2

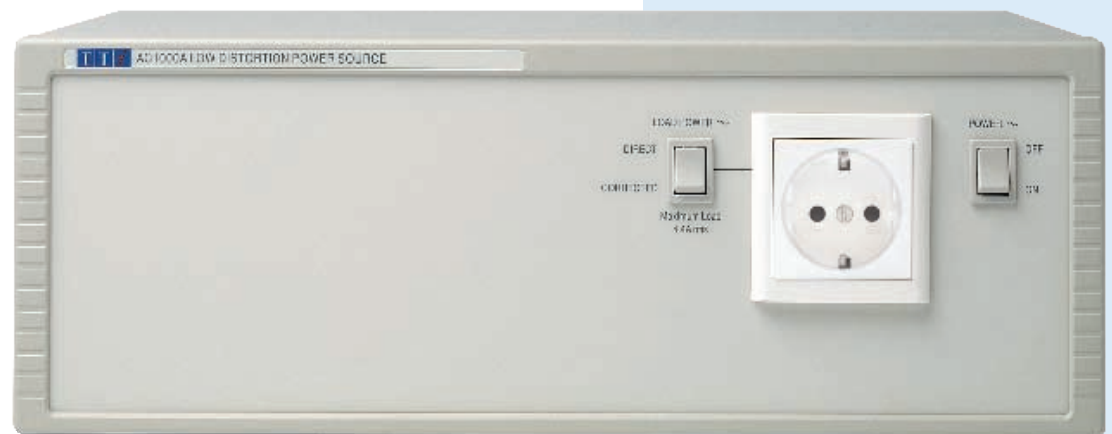

## Product Index

The page number index, together with general information about the company and its products, is on the inside of the front cover.

## The TTI Web Site

This catalogue provides only limited information on each product.

Detailed product information is provided on the TTI web site, together with support information and price lists.

The international web site is: **tti-test.com**

This has the alternative web address: **tti.eu**

UK customers can also use: **tti.co.uk** which is the web site of our UK sales division.

(Note that the leading www. is optional for all of our web addresses)

The screenshot shows the TTI website interface. At the top, it features the TTI logo and the tagline 'advanced electronic test instruments and laboratory power supplies'. Below this, there are contact details for the website: www.tti-test.com, Tel: +44 1480 412451, sales@tti-test.com, and Fax: +44 1480 450409. The main heading reads 'TTI - the Home of Test and Measurement Electronic Test Instruments and Power Supplies from TTI - Thurlby Thandar Instruments'. A navigation menu includes links for 'Contact TTI', 'About TTI', 'What's New', 'Support', 'Where to Buy', 'Price Lists', 'Site Map', and 'UK Customers'. Below the navigation, there is a section for 'DETAILED TTI PRODUCT INFORMATION' which states that products are divided into four main groups: Laboratory Power Supplies, Waveform Generators, Precision Measurement Instruments, and RF and EMC Test Equipment. Each group is accompanied by an image of representative equipment. At the bottom of the screenshot, there are two alternative links: 'VIEW A SUMMARY OF ALL TTI PRODUCTS' and 'VIEW THE VERY LATEST PRODUCTS FROM TTI'.

[tti-test.com](http://tti-test.com)

### Thurlby Thandar Instruments Limited

Glebe Road, Huntingdon, Cambridgeshire  
PE29 7DR England (United Kingdom)

#### Contact for international customers:

Web: [www.tti-test.com](http://www.tti-test.com)  
Telephone: +44 (0)1480 412451  
Faximile: +44 (0)1480 450409  
Email: [sales@tti-test.com](mailto:sales@tti-test.com)

#### Contact for UK customers:

Web: [www.tti.co.uk](http://www.tti.co.uk)  
Telephone: 01480 412451  
Faximile: 01480 450409  
Email: [sales@tti.co.uk](mailto:sales@tti.co.uk)



riešenia na presné meranie

Elsophilips Service  
Jilemnického 2; 911 01 Trenčín  
tel: +421 32 6582410, 7431690  
fax: +421 32 6582592  
email: [elso@elso.sk](mailto:elso@elso.sk)  
web: [www.elso.sk](http://www.elso.sk)