



PSC600-series DC/DC 300 - 800 W

The PSC600 series convection cooled DC/DC converters has a wide range of input and output combinations. The basic mechanical design is based around the Euro format 6HE 230 mm depth with two DIN 41612 H15 connectors on the back. However due to its sturdy aluminum case it can also be mounted in vehicle chassis or other type of cabinets. The basic design can accommodate two extra heat sinks to supply higher power or provide higher operating temperatures (e.g. EN 50155 T3). The input and output can also be supplied with M6 studs or circular connectors for Military applications with high demands on EMC immunity and also up to IP65 ingress classification. Polyamp can also provide so called hot swap power systems in 6U 19"-rack units or special ruggedized cabinets for mobile applications. Very high practical MTBF and CE marked as free standing unit. Operating temperature range -25 to +70 °C.



INPUT / OUTPUT

- Optimized input voltage from 24 to 440 V nominal battery voltages.
- Single outputs from 5 to 125 V.
- Zero Inrush current limit.
- Reverse input voltage protection

FEATURES

- Conformally coating, tropic.
- Alarm relay output.
- Accesible from front panel:
 - Output voltage adjustment.
 - Output voltage measurement.
 - Output OK status green LED.

INPUT AND OUTPUT RATINGS

INPUT			
Nominal inputs	Input range	Stop level	Code
24 Vd.c.	20 - 32 V	< 16.8 Vd.c.	24
48 Vd.c.	41 - 60 V	< 33.6 Vd.c.	48
110, 127 Vd.c.	93 - 150 V	< 77 Vd.c.	110
220, 250 Vd.c.	187 - 300 V	< 154 Vd.c.	220
440 Vd.c.	350 - 550 V	< 330 Vd.c.	440

Other input ranges on demand.

Input range, is the range we guaranty

full output performance, $U_{out} +10\%$ $I_{out} +5\%$.

The converter works down to the stop level.

The output voltage might decrease to approx -10% of nominal output voltage at the stop level.

OPERATION

- High efficiency > 90%.
- Operating temperature range -25 to +70 °C with no derating.
- Fully encapsulated, meets IP20 as standard.
- Convection cooled.

EMC

- EN 61000-6-3, Emission.
- EN 61000-6-2, Immunity.
- EN/IEC 61000-4-4, 4 kV.
- EN/IEC 61000-4-5 level 2 & 3.

OUTPUT		
Voltage	Current	Power
5 V	60.0 A	300 W
12 V	30 - 60 A	400 - 700 W
15 V	27 - 54 A	400 - 800 W
24 V	16 - 33 A	400 - 800 W
48 V	8 - 16.7 A	400 - 800 W
110 V	5.5 - 7.3 A	600 - 800 W
125 V	4.8 - 6.4 A	600 - 800 W

Higher voltage on demand

OUTPUT RATING & TYPE CODE

OUTPUT			INPUT					
Voltage	Current	Power	20 - 32 V	41 - 60 V	93 - 150 V	187 - 300 V	Case	6HE
5 V	60.0 A	300 W	PSC300 24/5	PSC300 48/5	PSC300 110/5	PSC300 220/5	46 mm	10TE
12 V	33.0 A	400 W	PSC400 24/12	PSC400 48/12	PSC400 110/12	PSC400 220/12	46 mm	10TE
12 V	42.0 A	500 W		PSC500 48/12	PSC500 110/12	PSC500 220/12	56 mm	12TE
15 V	27.0 A	400 W	PSC400 24/15	PSC400 48/15	PSC400 110/15	PSC400 220/15	46 mm	10TE
15 V	40.0 A	600 W		PSC600 48/15	PSC600 110/15	PSC600 220/15	56 mm	12TE
24 V	25.0 A	600 W	PSC600 24/24	PSC600 48/24	PSC600 110/24	PSC600 220/24	46 mm	10TE
24 V	33.0 A	800 W		PSC800 48/24	PSC800 110/24	PSC800 220/24	56 mm	12TE
48 V	12.5 A	600 W	PSC600 24/48	PSC600 48/48	PSC600 110/48	PSC600 220/48	46 mm	10TE
48 V	17.0 A	800 W		PSC800 48/48	PSC800 110/48	PSC800 220/48	56 mm	12TE
110 V	5.50 A	600 W	PSC600 24/110	PSC600 48/110	PSC600 110/110	PSC600 220/110	46 mm	10TE
110 V	7.30 A	800 W		PSC800 48/110	PSC800 110/110	PSC800 220/110	56 mm	12TE
125 V	4.80 A	600 W	PSC600 24/125	PSC600 48/125	PSC600 110/125	PSC600 220/125	46 mm	10TE
125 V	6.40 A	800 W		PSC800 48/125	PSC800 110/125	PSC800 220/125	56 mm	12TE

Other input and outputs combination on demand.

FEATURES

Over voltage protection OVL

A second independent regulation circuits limits the output voltage to 15% over nominal output voltage, in case the normal regulation fails.

Under voltage alarm

A built in alarm changes to alarm state if the converter output voltage drops 10% below nominal output. The DC OK LED is also controlled by the alarm circuit.

The alarm has an relay output with both [NO] and [NC] function. The relay rating is 30V 1A (a.c. & d.c.)

Reverse input voltage protection

On input code 24 and 48 the reverse voltage protection is provided by a parallel diode. This diode is only intended to blow an external input fuse.

On input code 110 and 220 the reverse voltage protection is provided by a series diode. The converter will never start.

Inrush current limit

On input code 110 and 220 the inrush limit circuit is always active thus acting at voltage dips below the stop level >10 ms. On input code 24 and 48 this function is optional.

Adjustment & measurement

Output voltage adjustment potentiometer and output voltage measurement points are accessible from the front panel.

Conformal coating

The PSC-series is conformally coated to withstand non-condensing tropical environment.

OPTIONAL FEATURES

Wider input range

The PSC600 series can be supplied with wide input range to meet train or mobile application demands.

Built in series diode - C

Series diode on the output, which is mounted inside the case. Use this option when the output is connected in parallel with other power supply to achieve redundancy.

Built in series diode with resistor - CR

The CR option automatically balance the load between 2 or more paralleled PSC600 units. Used in hotswap.

Remote Sense - S

The voltage sensing can be put at the load to compensate for voltage drop.

The sense circuit is a standard feature on 5 V outputs.

Inrush current limit

On input code 24 and 48 the inrush limit circuit is optional. This option affects the input voltage range. The circuit is always active thus acting at voltage dips below the stop level >10 ms.

Higher Insulation on output - E2

E2 - Output/case 2.5 kVa.c. for 12 to 125 Vd.c.

-40°C ambient temperature

Over Current Shut Down - OCSD

The PSC600 series can provide over current during a limited time.

The OCSD circuit shut down the unit when a preset time has passed. This delay can be pre-set between 100 ms to 3 seconds.

GENERAL DATA / INPUT DATA

LABEL	VALUE
Design topology	Push-Pull / Full-Bridge
Switching frequency	50 kHz
Emission / Immunity	See page 7
Safety EN/IEC 60950	Class I
Max. accepted input ripple 50-400 Hz	2 % of nominal voltage
Input power at no load	3 - 5 W
Reverse input voltage protection	
24, 48 input code	Parallel diode
110, 220 input code	Series diode
Insulation	See page 7
Dimensions and Weight	See page 4 to 6

OPTIONAL T-INPUT

DC INPUTS MOBILE		
U _{in} 0.1s-S2	Continuous range	Code
14.4 - 33.6 Vd.c.	16.8 - 30 Vd.c.	24T
21.6 - 50.4 Vd.c.	25.2 - 45 Vd.c.	36T
28.8 - 67.2 Vd.c.	33.6 - 60 Vd.c.	48T
43.2 - 100.8 Vd.c.	50.4 - 90 Vd.c.	72T
66 - 154 Vd.c.	77 - 137.5 Vd.c.	110T

The total output power can be derated on a T-range compared to the above output rating table.
Input according to EN 50155:2007 and IEC 60571:2011

PIN-OUT, SINGLE OUTPUT

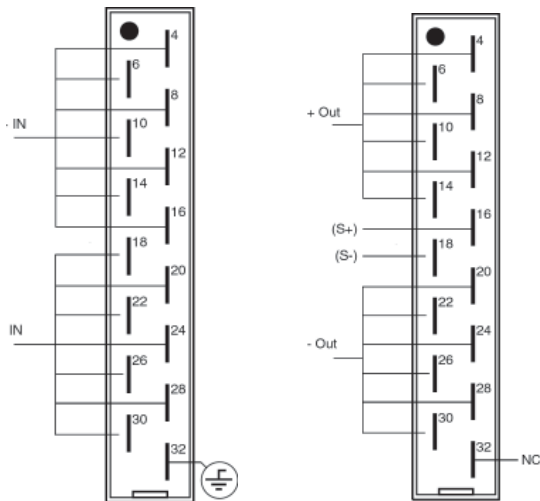

Figure 1. Pin-out with Connector DIN41612, H15.



Picture 3. Case 46 mm with wall mounting mechanics N and optional H15-S female screw connectors

OUTPUT DATA

LABEL	VALUE
Source regulation	0.2 %
Load regulation (0-100% load) master	0.2 %
Transient recovery time for a load step 10 to 90% voltage deviation.	< 2 ms 3%
Output ripple (50 kHz) V _{p-p} ² Input ripple attenuation on output 50 to 40 Hz	Typ. 20 mV 150:1
Emission / Immunity	See page 7
Temperature coefficient	0.02 %/°C
Output voltage adjustment range adjustable with a 15 turn potentiometer	90 to 110%
Current limit, rectangular	105%
Remote sense	Option 5
Soft start	Yes
Isolation output / case	See page 7 & opt. E2
Start-up time	1 s
Hold-up time, contact factory	2 - 25 ms
Efficiency ³	80 - 93 %
Operating temperature range at 100 % load. Conduction cooling Single outputs > 10 V	-25 to +70 °C
Operating temperature range at 100 % load. Conduction cooling Single outputs < 10 V	-25 to +55 °C
Storage temperature range	-40 to +85 °C

- Output ripple might increase when IEC/EN 61000-4-3 20 V/m test is applied to max 0.5% VRMS
- Lowest efficiency measured within the whole input voltage range at 100% load.

Standard connector



Picture 1. FastOn 6.3mm tab Connector H15-T

Option connector



Picture 2. H15 female Screw Connector H15-S



Picture 4. Case 56 mm with wall mounting mechanics N, front view

N-MECHANICS: WALL & CHASSIS MOUNTING WITH H15 CONNECTORS

The standard version of PSC600 series is this N-mechanics, which includes H15 connector holder and 2 x H-15-T female connector, see page 3. Next page shows PSC600 series with M6 screws that is an optional connection method using the same basic mechanics. The basic case can be added with one or two extra heat sinks. Depending on output power or options. Its also possible to mount against a larger heat sink, by using spacers. The spacers also fix the H15 connector. Optionally TS-35 DIN mounting clips can be provided.

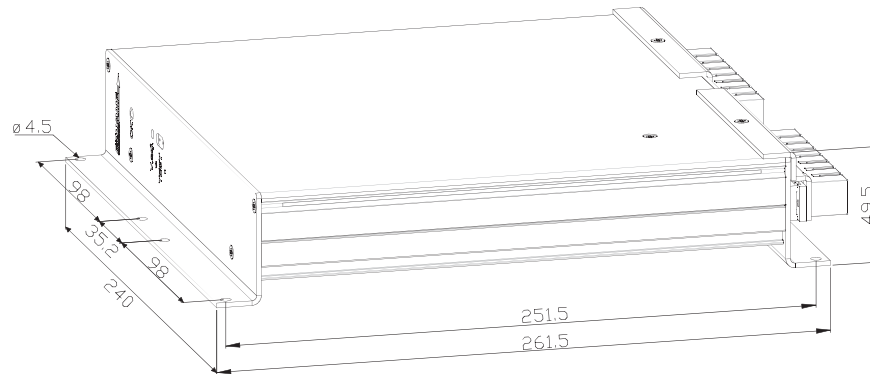

Figure 5. Side view PSC600 with option N

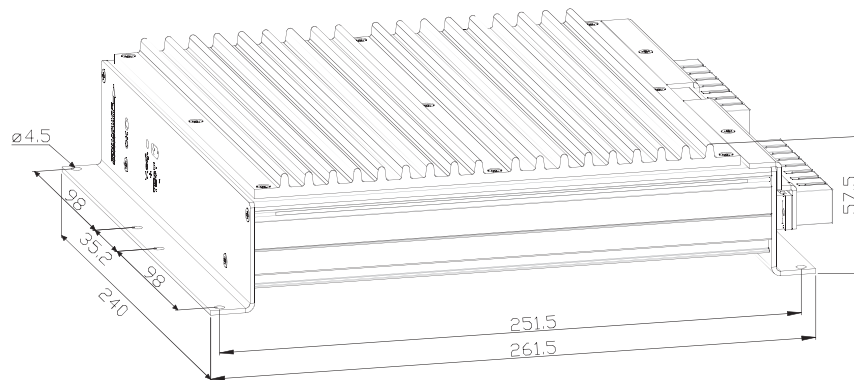

Figure 6. Side view PSC800 with option N

Mechanics	Weight
Base mechanic unit	3.3 kg
Base mechanic unit + one extra heat sink	4.0 kg
Base mechanic unit + two extra heat sinks	4.7 kg

The PSC600-family are built in aluminium extrusion, with high thermal conductance which also work as a good EMC shield. The mechanical design permits use in vehicles and heavy industrial environments. The IP class is IP20.

Vibration and shock/bump are based on IEC 60721-3-5 Ground vehicle installations Class 5M2 with random vibration according to IEC 60068-2-64 and bump IEC 60068-2-27:2008 which are 3 dimensional tests.

The vibration test has a 1.68 gRMS value during a certain time. In trains its 5 h according to IEC/EN61373. The bump is tested at 30 g, 6 ms. The PSC600 series has also been tested in military vehicles.

Military grade version of PSC600 series is shown on Picture 6, page 8. Depends on the customer requirement to be mentioned:

Input: MIL-STD 1275E; MIL-STD 1399-390

EMC: MIL-STD 461F RS-103 up to 200 V/m

Environment: MIL-STD 801 (customer specification); IP54/IP65

N-MECHANICS: OPTION M6, STUDS / SCREW CONNECTORS

PSC600 family with N-mechanics and M6 Screws/Studs called the N-mechanics with B-option. The standard version has a connector with remote sense, see option S, and relay NO, NC relay function. The unit is also supplied with a Polycarbonate electric touch safety cover. For higher Ingression Protection IP rating we use panels that are fully covered (except the connectors) without Sense and Alarm connectors.

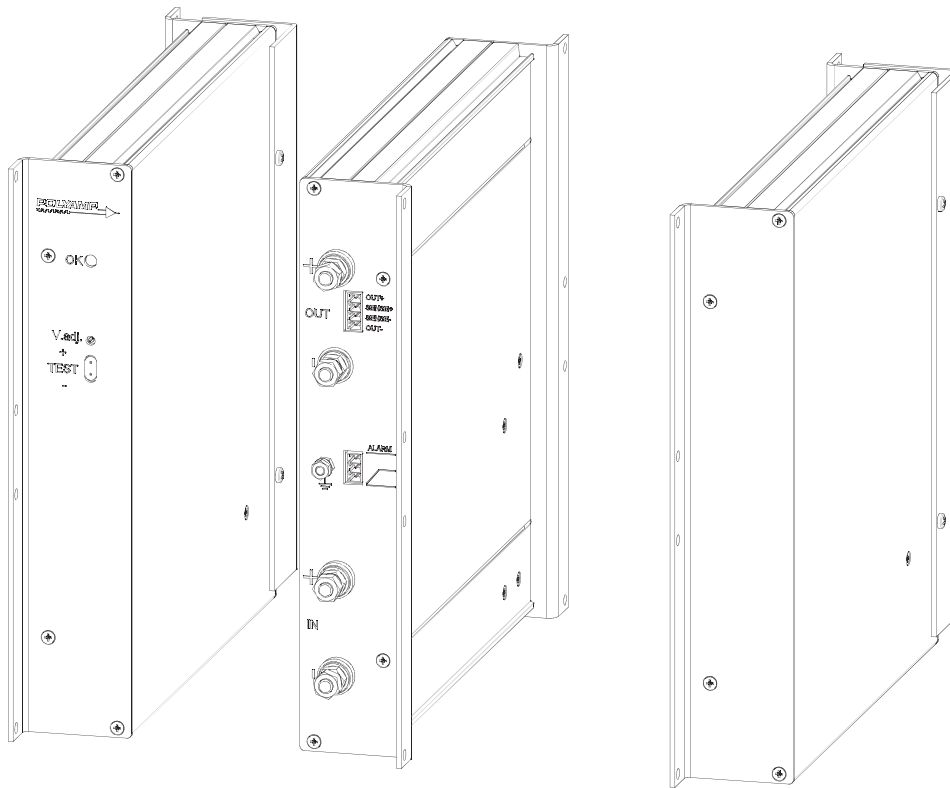

Figure 9. Front panel

In / Out panel with M6 bolts/studs

Optional sealed panel for higher IP grade up to IP54.

Dimension: Please see Figure 5 and 6, page 4.

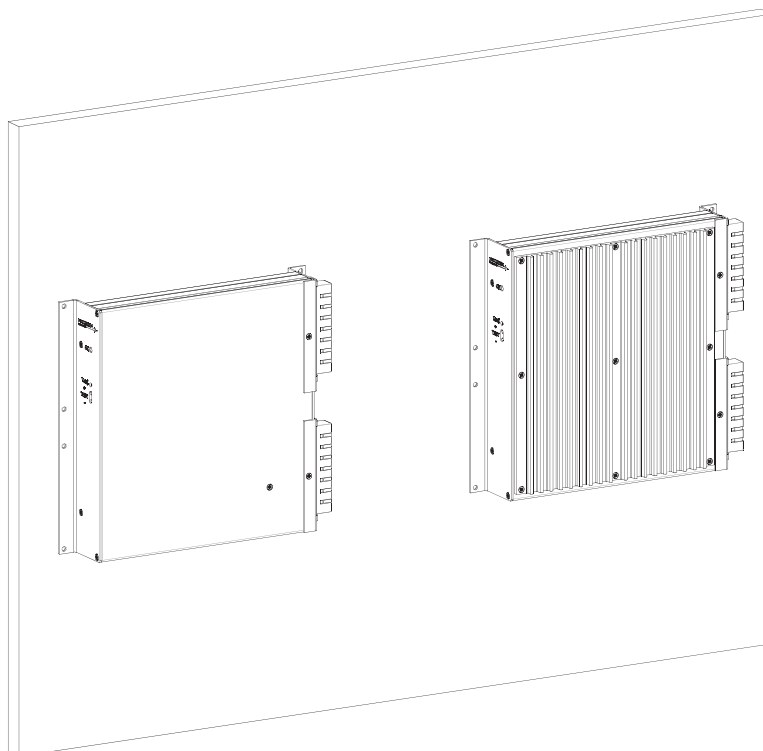

Figure 8. Recommended mounting direction.

L-MECHANICS: OPTION L, 6HE FOR 6U 19"-SUBRACK PLUGG-IN MODULES

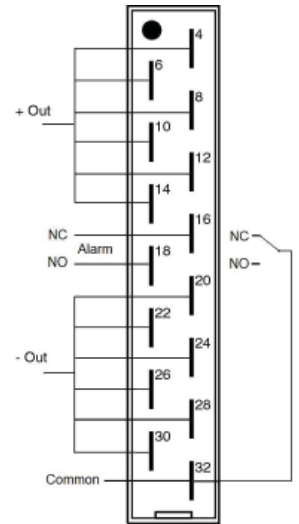
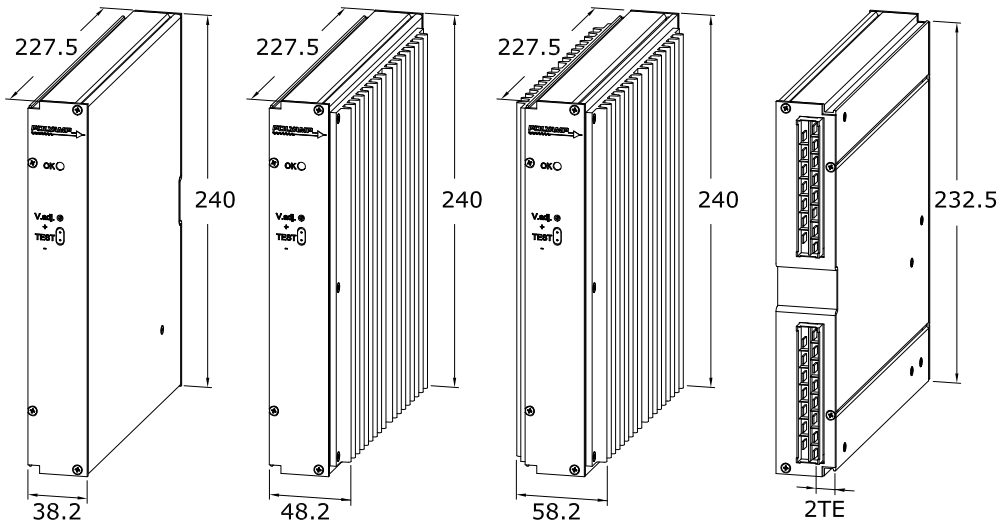

Figure 2. Front view

Back view

Figure 3. The alarm signal

The 6HE mechanics is intended to be mounted in 19"-subrack as plug-in module. Either the unit is mounted behind a covering door as figure 2 units or as plug-in module with optional 8, 10, 12 or 14 TE panels as displayed in figure 4.

Option Panels: 8TE (care about cooling distances). 10TE, 12TE and 14TE.

Alarm signal: The 6HE version has no separate alarm connector. The alarm signal is connected according to figure 3 on the output connector.

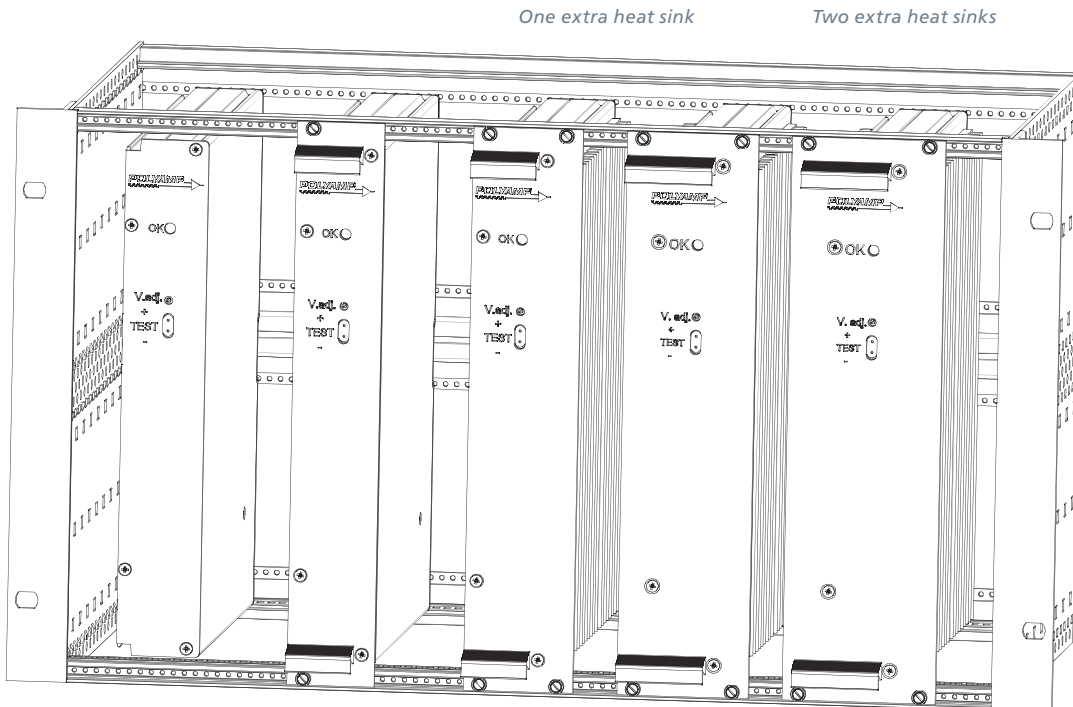

Figure 4. Mounted in a 6U 19"-subrack, without panel, with 8TE, 10TE, 12TE and 14TE panel.

Option: Aluminium Guiders for Schroff cabinets

Mechanics	Weight
Base mechanic unit	3.3 kg
Base mechanic unit + one extra heat sink	4.0 kg
Base mechanic unit + two extra heat sinks	4.7 kg

SAFETY AND EMC

PSC-series meets the requirements defined by CE mark as apparatus. PSC-series meets requirements of EMC directive and low voltage directive (LVD).

Thus a PSC-series can be used as free standing unit or in installations as well as systems designed according to "The modular approach". PSC-series can be used in installation without further EMC tests, if our installation instructions are followed.

Please note that product standards can demand different levels or other basic standard tests. We test according to levels below. For higher levels or other tests, contact factory. http://www.else.sk/product.php?hl_product=2354

SAFETY STANDARD EN/IEC 60950

ISOLATION TESTABLE LEVELS	TEST VOLTAGE
Input / Output	2.5 kVa.c. / 4 kVd.c.
Input / Case	2.5 kVa.c. / 4 kVd.c.
Output / Case all outputs	2 kVd.c.
ISOLATION TESTABLE LEVELS	SAFETY ISOLATION
Transformer isolation In / Out	4 kVa.c. / 8 mm

We use the product standard Low voltage power supplies, DC outputs EN/IEC 61204-3.

The EMC level follows the generic EMC standards:
EN/IEC 61000-6-2 (Immunity)
EN/IEC 61000-6-3 (Emission)

EMC

EMC STANDARDS	EMC-PERFORMANCE		
Emission standards	Input	Output	Remarks
EN 55016 / CISPR16 (0.15-30 MHz)	OK	OK	
EN 55016 / CISPR16 (30-1000 MHz)	OK		Enclosure test
Immunity standards	EN/IEC 61000-6-2		
EN/IEC 61000-4-2	8 kV / 15 kV		Contact / air, Enclosure test
EN/IEC 61000-4-3	20 V/m AM-Modulated		Output ripple can increase to 0.5 % of Vout. Enclosure test
EN/IEC 61000-4-4	4 kV	4 kV	
EN/IEC 61000-4-5, Input code 24, 48	0.5 kV / 1 kV	0.5 kV / 1 kV	Line-line 2 Ω / Line-case 12 Ω
EN/IEC 61000-4-5, Input code 110 ¹ , 220 ¹	1 kV / 2 kV	0.5 kV / 1 kV	
EN 50121-3-2 / IEC 62236-3-2	1 kV / 2 kV	1 kV / 2 kV	Line-line 42 Ω / Line-case 42 Ω
EN/IEC 61000-4-6	10 V _{RMS}	10 V _{RMS}	AM-Modulated
EN/IEC 61000-4-8	30 A/m		Enclosure test
EN/IEC 61000-4-10	Not sensitive		Enclosure test

1. Higher level 2 kV / 4 kV with external filters, contact factory.

Note:

All PSC600 series models meets Railway EMC standards EN 50121-3-2 and EN 50121-4 (IEC 62236-3-2 and IEC 62236-4).mj



Elso Philips Service
Jilemnického 2; 911 01 Trenčín
tel: +421 32 6582410
fax: +421 32 6582592
email: elso@elso.sk
web: www.else.sk



Picture 5. 19" rack for a special project in a power plant.



Picture 6. Military grade version of PSC600 series.



Picture 6. The Switch Craft Plant, 1100 m above sea level

Switch Craft Plant

Switch Craft S.A. is located in La Chaux-de-Fonds in the Jura mountains in Switzerland. The main products are the Eurocassette families of PSC and PSE converters. Polyamp supports the sales and marketing activities but Switch Craft handle all support to the distributors.



HEAD OFFICE

Polyamp AB
Box 925
SE-191 29 Sollentuna
Sweden
Phone: +46 8 594 693 00
Telefax: +46 8 594 693 05

SALES OFFICE

Polyamp AB
Box 229
SE-597 25 Åtvidaberg
Sweden
Phone: +46 120 854 10
Telefax: +46 120 854 05

SALES OFFICE

Switch Craft S.A.
Ruel bel Air 63
CH-2300 La Chaux-de-fonds
Switzerland
Phone: +41 32 96 78800
Telefax: +41 32 96 78809

Email: info@polyamp.se
www.polyamp.com

Installation Manual

DC/DC converters

PSC300, PSC400, PSC600, PSC700, PSC800



PSC600 for 6HE 8TE mounting



PSC600 wall/chassis mounting option N



Connector assembly option N,
with optional H15 screw
connection females and
connector holders.

Warranty

All Polyamp DC/DC converters are warranted against defective material and workmanship. This warranty is valid for 24 months from the date of delivery.

We will repair or replace products which prove to be defective during the warranty period. The warranty is valid only if the converter is used within specification.

Manual

This manual is as complete and actual as possible at the time of printing. However, the information may have been updated since then. Polyamp AB reserves the right to make changes in this manual without notice.



The exclamation point within an equilateral triangle is intended to alert the user to presence of important operating and maintenance instructions in the literature accompanying



The lightning flash with arrowhead, within an equilateral triangle, is intended to alert the user to presence of un-insulated "dangerous voltage" within the products enclosure that may be of sufficient magnitude to constitute a risk of electric shock to persons

Caution!

To prevent the risk of electric shock, do not open enclosure. No serviceable parts inside. Refer servicing to qualified service personnel only



We supply a separate declaration of conformity within our shipment that mainly refers to the Low voltage directive and EMC directive.



INSTALLATION MANUAL
PSC600 series

1	Before installation	4
1.1	Cable and pin dimensioning.....	4
1.2	Reverse polarity protection.....	4
1.3	Input fuse	5
1.4	Inrush current limit	5
2	Installation.....	5
3	Parallel connection	7
3.1	Series diode on the output, option C.....	7
3.2	Series diode with series resistor, option CR	7
3.3	Output under voltage alarm	7
3.4	Connecting systems in N+1 configuration.....	7
3.5	Connecting converters in parallel on the output	8
3.6	Adjusting output voltage when units are paralleled on the output.....	8
5	Multiple loads at the output.....	9
5.1	Short-circuits.....	9
6	Output voltage sense, option S.....	10
7	Output over voltage protection OVP.....	10
7.1	Standard feature	10
7.2	OVP option A	10
8	Under voltage Alarm relay	10
9	Higher isolation voltage, Option E1 & E2	11
10	Insulation voltage test.....	11
10.1	DC isolation test output to case.....	11
10.2	AC isolation test output to case, option E2	11
10.3	DC isolation test input to output and input to case	12
10.4	AC isolation test input to output and input to case	12
11	Trouble shooting	13
11.1	There is no or wrong output voltage	13
11.2	The input fuse blows when the input is connected.....	13
11.3	The converter starts and stops repeatedly	13
11.4	Fault report	13

1 Before installation

Before installation, please read this section and minimum section 2. This installation manual shall also be read together with the datasheet of the product. Download the datasheet from www.polyamp.com and check the File archive where in section Datasheet you will find PSC600.pdf.

If any problem occurs during installation please check *section 11 Trouble shooting*. This product family is called PSC600.

The product is labelled as below example:

<p>PSC600 110/24 Input: 110Vd.c.: 6 A; Input range: 88 – 150 Vd.c. Output: 24V 25A Option: L, C</p>
--

The DC/DC converter type name consists of model name PSC300, PSC400, PSC600, PSC700 and PSC800 followed by input code and output voltage. Two examples:

- **”Type: PSC600 24/48”** has input code **”24”** and nominal output voltage **48 Vd.c.** The 600 indicates around 600 W output power.
- **”Type: PSC800 110/24”** has input code **”110”** and nominal output voltage **24 Vd.c.** The 800 indicates around 800 W output power.

The **Options** are block letters separated by comma(.). You will find explanation within this manual what the letter code means.

The **input** states the nominal input voltage and **maximum input current** at any conditions. It means the output is adjusted +10% above nominal voltage and close to the current limit, which is the stated output current +5% and a lowest input voltage level.

Input range is the input range that the unit can operate normally.

Output indicates the nominal output voltage and the rated current.

The output is current limited with a so called rectangular characteristic. When the current limit is reached, which is adjusted to +5% of above mentioned nominal output current, this is the maximum current that will continuously flow. The output voltage drops very quickly down towards zero volt (depends on the series resistance of the load circuit as the unit can be regarded as a constant current generator at over current condition). We have no time limit on over current condition.

Temperature range is the rated operation temperature at 100% load condition.

Input, output and case are galvanically separated from each other. This is a **Class I Insulation system**, which is dependent of correct earth connection on the input. All outputs are insulated from case with minimum 2000 Vd.c. *Section 10 Insulation voltage test*, describes the insulation rating depending on input voltage. See *section 9* if higher insulation is required.

Series number is stamped on the panel under the connector

1.1 Cable and pin dimensioning

The PSC600 series is using two DIN 41621 H15 connectors intended for 6HE Euro format mounting. Each pin has a continuous current rating of 15A @+55°C and 12A @+70°C ambient temperature.

All pins in one pole are parallel connected internally, *see Figure 1*. Therefore on C, D, 110, and 220 inputs only one input pin per pole needs to be used. It is also possible to supply 6 different outputs/loads or use a limited number of pins depending on the output current. E.g. 24V 25A only need two pins.

1.2 Reverse polarity protection

The input is protected from reverse polarity. The method used is dependent of the input.

On A, B, 24, 36 input a parallel diode is used that is dimensioned to blow an external fuse.

On C, D, 48, 72, 110, 220 input a series diode is provided. The converter will not start if reverse voltage is applied.

It is possible to use series diode on input A, B, 24, 36 with derated performances due to higher power losses.

Please contact your local distributor or factory, for more information.

1.3 Input fuse

The input should be fused with an approved fuse with a slow blow characteristic and high breaking capacity. Select a stand current rating equal or above the below specified value, see *Table 1 to 3*.

Input voltage code	Slow blow fuse PSC400
A	46 A
B	23 A
C	10 A
D	5 A

Table 1. Recommended input fuses.

Input voltage code	Slow blow fuse PSC400	Slow blow fuse PSC600	Slow blow fuse PSC800
24	25 A	37 A	63 A
48	13 A	19 A	25 A
110	5 A	7.5 A	12 A
220	2.5 A	3.7 A	6 A

Table 2. Recommended input fuses.

Input voltage code	Slow blow fuse PSC400	Slow blow fuse PSC600	Slow blow fuse PSC800
24T	31 A	47 A	63 A
36T	25 A	35 A	50 A
48T	16 A	24 A	35 A
72T	12.5	16 A	25 A
110T	7 A	10 A	15 A

Table 3. Recommended input fuses.

There are two reasons we do not include an input fuse:

1. DC-networks should be fused at the distribution point to protect the cable.
2. Different applications require different types of fuses.

A switching device able to switch off both polarities input cables has to be mounted externally. The switching device shall be

marked accordingly and easy accessible. If the converter is mounted in an electric vehicle, an external series diode on the input is recommended. Please contact your Polyamp dealer.

1.4 Inrush current limit

The input capacitors are charged through an active inrush current limit circuit that reduces the input inrush current during start up. This feature is standard on the PC600 series with input codes C, D and 48, 72, 110, 220.

For B and 24, 36 input codes the inrush current limit circuit is optional. On those this circuit will affect the input voltage range and the output power due to voltage drop losses in combination with high input currents.

All models has an "output soft start" that do not increase the input current above the unit rated current during start up (approx.. 0.1s).

2 Installation

The converter is designed to be mounted in a 6HE 19" sub rack unit, in such case the L-version must be ordered.

The PSC600 version with N mounting, a location only accessible for service, which meets the demand of EN60950 regarding fire enclosure, voltage hazard protection and mechanical strength, shall be used.

With option N, wall mounting set you can mount the converter in any direction on a wall or with optional mounting clips on DIN rail TS35. The converter is convection cooled and in order to get sufficient cooling there shall be a free air around the converter. If this is not possible, we recommend the use of an external fan.

Note that the expected life of the converter is dependent on converter temperature. For every 10°C that the temperature is lowered the expected life is approximately doubled. It is therefore crucial to cater for good ventilation and if possible to reduce ambient temperature.

To meet the EMC specifications in the enclosed "declaration of conformity" use

twisted-pairs for connecting input, output and alarm. Shielded cables are not necessary.

If the converter supplies a DC-motor, we recommend an external parallel diode at the motor poles to protect against reverse voltages.

Installation in a 6HE 19" Euro sub rack:

1. Check the pin-out, *see Figure 1*. Connect the protective earth pin 32 on the input connector. This provides safety against electrical shock and is required to achieve EMC performance according to the declaration of conformity.
2. Be aware that if the sense option "S" is provided the sense must be connected to the sensing point of the output and cannot be left open. *See section 6*.
3. Plug in the unit. Go to point 3 below.

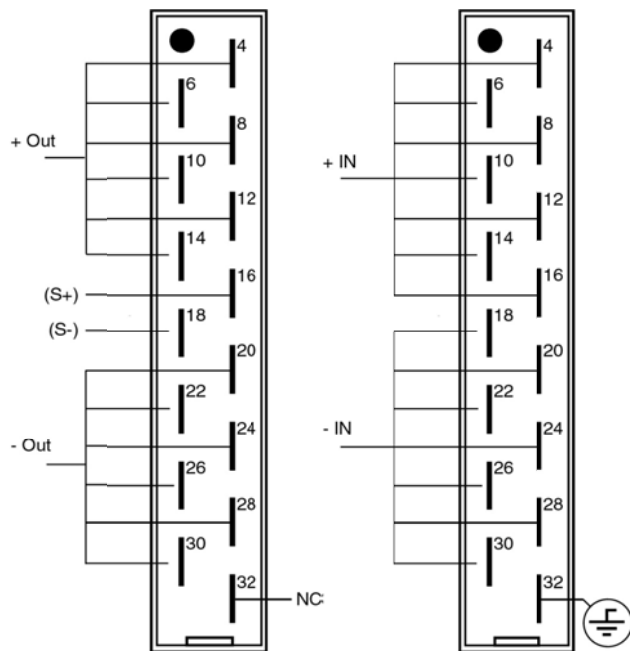

Figure 1. Pin-out on OUTPUT and INPUT DIN41612 H15 connectors.

Installation with wall mounting panel option N:

1. Check the pin-out, *see Figure 1*. Connect the protective earth pin 32 on the input connector. On bolt/studs connector models the protective earth is a separate screw. Protective earth provides safety against electrical shock and is required to achieve EMC

performance according to the declaration of conformity.

2. Connect the output. Be aware that if the sense option "S" is provided the sense must be connected to the sensing point of the output and cannot be left open. *See section 6*. Bundle the output cables together, separate from input.
3. The converter output is short-circuit proof by a constant current limit which works unlimited in time. Therefore there is no need to fuse the load (unless you use multiple loads, see below). The current limit is fixed to 105% of nominal output current.
4. Features and options
 - If the converter is to be connected in parallel at the output, please *consult page 7*.
 - If you use multiple loads, please *consult section 5 Multiple loads at the output on page 9*.
 - If you intend to use alarm feature, please *consult Under voltage Alarm on page 10*.
 - The output have an over voltage limit circuit that is set +15% of nominal output. *See also section 8 OVP option, page 10*.
5. Connect the input cables. Bundle input cables together separated from the output cables.
6. Start the converter by inserting your input slow blow fuse to your DC voltage supply. Sparks may occur when the input capacitors are charging.

Beware of hazardous voltages!

The output voltage can be adjusted $\pm 10\%$ of the nominal output voltage with the potentiometer marked V.ADJ on the front panel. Clockwise turn increases the output voltage. The potentiometer has 15 turns. If you have connected units in parallel on the output, the procedure of adjusting the output voltage is described in *section 3.6 Adjusting output voltage when units are paralleled on the output on page 8*.

3 Parallel connection

If a redundant power supply system is requested, two or more converters can be connected in parallel. To achieve redundancy the number of converters must be dimensioned to carry the whole load even if one converter is faulty. The option C or CR series diode on the output must be provided. Connect your load to the + output after the series diode (cathode).

Another reason for connecting two or more converters in parallel is to get more power. The option C must be provided. When the series diode C or CR option is used the *Sense option S*, see section 6 page 10, cannot be used.

3.1 Series diode on the output, option C

A series diode is necessary if the output is connected in parallel with another power supply or if you require redundant operation. If a converter breaks down with an internal short-circuit on the output and other converters are connected in parallel on the output, the broken unit will short-circuit the others if the series diode is not used. This might cause excessive heat or even fire in the faulty unit. The series diode protects the converter output from external voltage sources.

3.2 Series diode with series resistor, option CR

This option is an extension of 3.1 Series diode. When several PSC600 units are connected in parallel with so called "hot plug in" in 19" sub-rack, a built in series resistor and series diode is provided that will automatically balance the current between units.

The series resistor will provide the Ud function described in section 3.4 and figure 45. Thus no special cable arrangements are needed with this CR option.

3.3 Output under voltage alarm

If one DC/DC converter fails in a redundant power system an alarm signal should be detected.

The PSC600 has relay output as a standard feature, see section 8.

3.4 Connecting systems in N+1 configuration

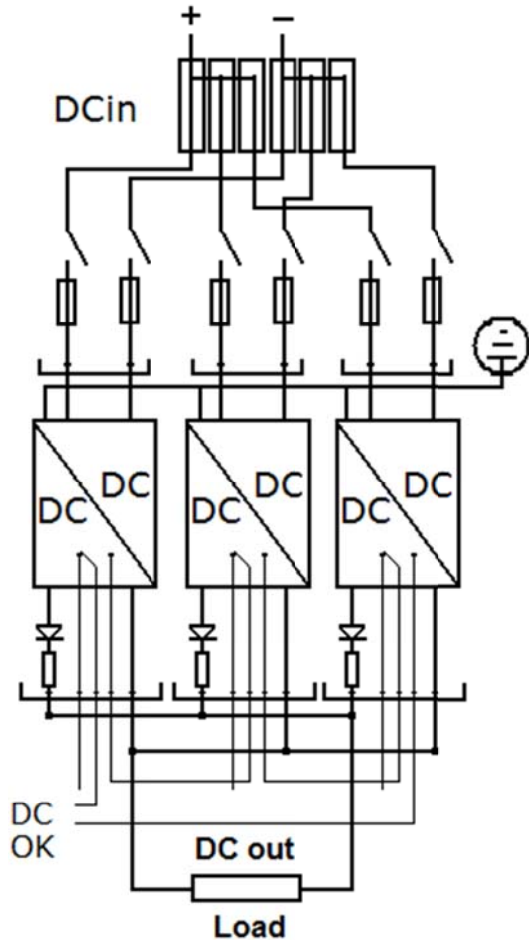

Figure 2. An N+1 system with two units for the load and one for the redundancy.

The Figure 2 shows an N+1 system with two units for the load and one for the redundancy. Each DC/DC converter has a built in; series diode (C), balancing resistor (R) and alarm relay outputs. The alarm is cascade connected. Note that each DC/DC converter has individual external input fuses.

With the CR option a hot plug-in can be achieved if the output voltage is correctly adjusted. Use instruction in section 3.6 -3 below.

3.5 Connecting converters in parallel on the output

The expected life of the converter is dependent on converter temperature. It is therefore important for paralleled unit to share the load as equal as possible to reduce the converter temperature. To achieve good current sharing the converters must have separate cables to the load. The cables should be dimensioned to have a voltage drop, U_d , between the converter and the load at maximum current capacity, see *Figure 3 and Figure 4*.

- When the series diode is used, which we recommend, the voltage drop should be approximately 1.0% of nominal output voltage (to also compensate for the negative temperature coefficient of the diode).
- When the series diode is **not** used, **this is not recommended**, the voltage drop should be approximately 0.5% of nominal output voltage.

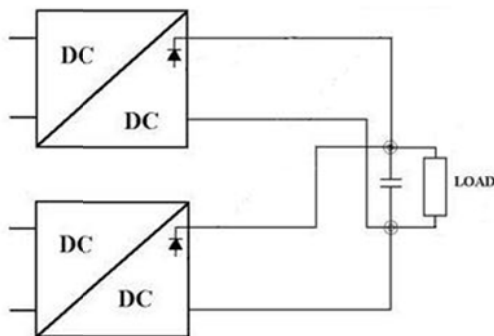

Figure 3. Parallel connection, with optional capacitor.

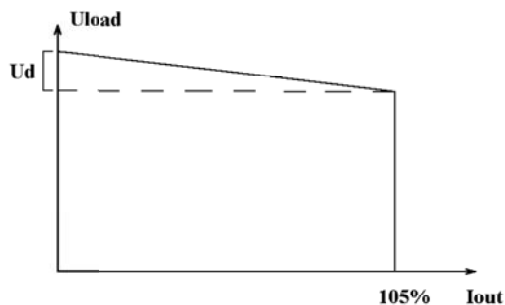

Figure 4. Load regulation with voltage drop U_d between output and load

Note that the voltage drop affects the load regulation (the voltage at the load), see *Figure 4*.

3.6 Adjusting output voltage when units are paralleled on the output

1. Connect and start all converters according to *Installation on page 6*. We recommend using the series diode and separate cables as mentioned above in *3.5 Connecting converters in parallel on the output* or the *CR option 3.2*.
2. Measure the voltage at the load. Connect voltmeters as showed in *Figure 5*. If you have only access to one voltmeter you must move it around to make the adjustments.

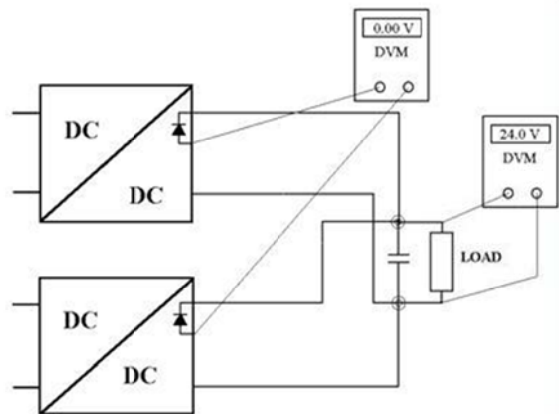

Figure 5. Adjusting output voltage measure at +Test or pin 8 on the H15 connector.

3. To **increase** the output voltage. Increase the output voltage by turning the potentiometer marked "V.ADJ" clockwise on the unit with the lowest output voltage until you reach the desired voltage at the load or until the output voltage does not increase anymore (as the unit is in current limit). To find the unit with the lowest output voltage you can measure the voltage difference before the series diode, as in *Figure 5*. Repeat from i. until you reach the desired output voltage at the load.
4. To **decrease** the output voltage.
 - i. Decrease the output voltage by turning the potentiometer marked "V.ADJ" counter clockwise on the unit with the highest output voltage until you reach

the desired voltage at the load or until the output voltage does not decrease anymore (as the other units supply all current). To find the unit with the highest output voltage, measure the voltage difference before the series diode, as in *Figure 5*.

- ii. Repeat from i. until you reach the desired output voltage at the load.
5. To achieve good current sharing, adjust all converters so that the voltage difference before the series diode is 0.00 V between all units that are connected in parallel and so that the voltage at the load is still the desired.

5 Multiple loads at the output

If you are using several loads, we recommend fusing them separately with fast acting fuses. Some considerations regarding short-circuits should be taken.

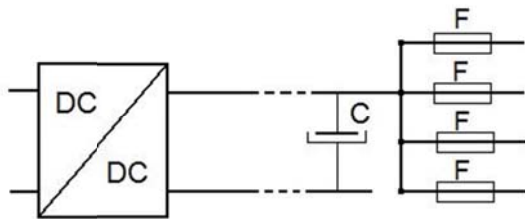

Figure 6. Connecting multiple loads.

5.1 Short-circuits

1. If there is a short circuit in one branch and the total current in all branches **does not exceed 105%** of the nominal current of the converter (see label on front panel), the output voltage will not be affected. The time for the fuse to blow can be calculated from the data sheet of the fuse if you know the short circuit current through the fuse.
2. If there is a short circuit in one branch and the total current in all branches **does exceed 105%** of the nominal current of the converter, the output voltage will drop until the fuse is blown. Depending on the impedance of the short circuit (whether it is abrupt or merely an overload) and the resistance of the load cables, the effects of a short circuit will vary.

Long cables reduce short-circuit currents, resulting in longer delay until the fuse is blown and hence an increased voltage dip. Light overload does not necessarily result in a blown fuse.

To reduce the voltage drop at short-circuit and if any branch has more than approximately 30% of the total output current of the converter, a large external capacitor is recommended. Such a capacitor will supply the peak current needed to blow the fuse, see *Figure 6*. To calculate the capacitor needed, use the following formula:

$$C = 1.2 \times (IS \times \Delta t) / \Delta U$$

1.2 = Safety margin.

IS = Short-circuit current through the fuse.

Δt = Time before the fuse blows (see data sheet on the fuse).

ΔU = Acceptable voltage dip before the fuse blows.

Example:

You have a 1A fuse with fast characteristic and the short-circuit current is 10A. The data sheet gives you that $\Delta t = 10\text{ms}$. The output voltage is 24V, and you can accept 10% voltage drop $\Rightarrow \Delta U = 24 \times 0.1 = 2.4\text{V}$.

The capacitance you need:

$$C = 1.2 \times (IS \times \Delta t) / \Delta U = 1.2 \times 10 \times 0.01 / 2.4 = 50,000\mu\text{F}$$

Choose a capacitance with a rated voltage of at least 115% of nominal output voltage of the converter.

Repeat this calculation for all branches and choose the highest capacitance value.

It is sometimes difficult to estimate the short-circuit current when the nature of a fault is unknown. In this case a voltage dip might appear under some short-circuit conditions even with a large capacitor present. If a voltage dip is critical in one branch it is recommended to use a separate DC/DC converter supplying this branch.

6 Output voltage sense, option S.

The remote voltage sense is used to improve the regulation at the load. The voltage regulation is moved to a point outside the converter where the sense is connected. Longer sense leads than 3 m is not recommended. The voltage difference between the load and the converter should not be larger than the output voltage range. Use twisted sense wires, see Figure 7.

The sense leads must always be connected to respective pole, even if not used externally. The sense cannot be used in a paralleled system, described in section 3.

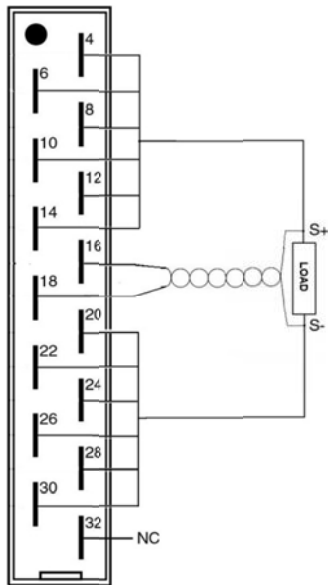

Figure 7. Remote sense connection.

7 Output over voltage protection OVP

7.1 Standard feature

In case the regulation circuit fails on the output, a secondary regulation circuit limit the output voltage level. The circuit also protects the converter output from external voltages. The trigger voltage is set to 115% to 120% of the nominal voltage. The circuit is active as long as the over voltage condition remains.

7.2 OVP option A

An independent circuit using a SCR thyristor is used as over voltage protection. When activated it short circuits the output. Reset a triggered OVP by switching off and on the input voltage.

The circuit protects the converter from high external voltages as well as regulation failures of the unit. The OVP trigger voltage is set to 115% to 120% of the nominal voltage. OVP is standard on all 5 V master outputs and will trigger at max. 6.2 V.

8 Under voltage Alarm relay

The alarm has dry contact output with selectable NO, NC function. The relay output is insulated from both input and output 2.5 kVa.c., see Figure 10.

The relay is rated 30V 0.5A (a.c. & d.c.).

For higher voltage/current relay rating please contact Polyamp.

On versions for 6HE 19"-subrack mounting option L the alarm is transferred to pin 16 and 18 and have a NC function.

The alarm relay can be connected in two ways:

1. Normally Open (NO). Connect twisted-pair (0.25 mm² - 0.5 mm²) from centre pin of the removable alarm connector and connector pin marked "NO".
2. Normally Closed (NC). Connect twisted-pair (0.25 mm² - 0.5 mm²) from centre pin of the removable alarm connector and connector pin marked "NC".

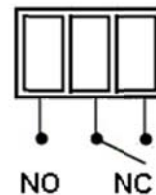

Figure 8. UL alarm with internal relay. Relay symbol shows Alarm state.

9 Higher isolation voltage, Option E1 & E2

E1 is 2 to 2.5 kVa.c. 1 minute between input and output, input and case. The emission level is increase to level A.
On PSC600 series with input ranges from 110 to 220 and C, D input ranges this is a standard feature.

E2 is 2 to 2.5 kVa.c. 1 minute between output and case. The emission level is increase to level A.

10 Insulation voltage test

Each converter has been isolation tested in factory before delivery. Please note that consecutive insulation test damage the Y-capacitors and affect the EMC performance of the unit. We ask you therefore to minimize or completely avoid such test.

The insulation voltage is 2.5 kVa.c between input and output, input and case. The output to case isolation is 2 kVd.c. on all models. Option E2 can increase this isolation.

If your isolation test equipment cannot supply the AC current, you can perform a DC isolation test with 4000 Vd.c ($2500\text{ V} \times \sqrt{2} \times 1.1 \approx 4000\text{ Vd.c}$ where 1.1 = safety factor).

10.1 DC isolation test output to case

1. Disconnect all cables from the converter.
2. Connect the input terminals of the converter to case.
3. Connect the output terminals together.
4. Connect your isolation tester between output and case. See *Figure 9*.

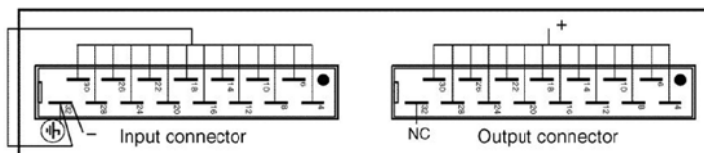

Figure 9. Output to case isolation voltage test.



An insulation test shall only be performed by personnel aware of the dangers and hazards of the test.

5. Raise the voltage of the isolation tester from 0 to 2000 Vd.c. (With option E2 0 to 4000 Vd.c.) Check that the leakage current does not exceed $5\ \mu\text{A}$. The voltage should not be applied for more than a few seconds or the Y-capacitors might be damaged.
6. Turn off the isolation tester and discharge the test voltage with a $10\ \text{M}\Omega$ resistor between output and case.

10.2 AC isolation test output to case, option E2

Beware of the rather high capacitive earth currents (about 100mA) that will occur during this test.

1. Disconnect all cables from the converter.
2. Connect the input terminals of the converter to case.
3. Connect the output terminals together.
4. Connect your isolation tester between output and case. See *Figure 9*.
5. Raise the voltage of the isolation tester from 0 to 2500 Va.c. The voltage should not be applied for more than one (1) minute or the Y-capacitors might be damaged.
6. Turn off the isolation tester and discharge the test voltage with a $10\ \text{M}\Omega$ resistor between output and case.



Warning!

An insulation test shall only be performed by personnel aware of the dangers and hazards of the test.

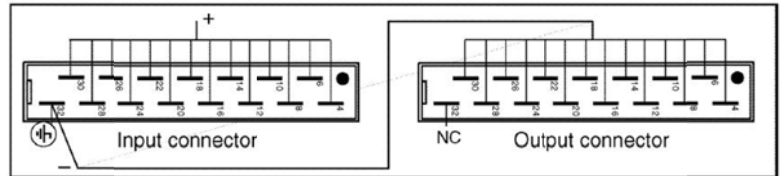

Figure 10. Input to output and input to case isolation voltage test.

10.3 DC isolation test input to output and input to case

1. Disconnect all cables from the converter.
2. Connect the output terminals of the converter to case. See *Figure 10*.
3. Connect the input terminals together.
4. Connect your isolation tester between input and case. See *Figure 10*.
5. Raise the voltage of the isolation tester from 0 to 4000 Vd.c. Check that the leakage current does not exceed $5\mu\text{A}$. The voltage should not be applied for more than a few seconds or the Y-capacitors might be damaged.
6. Turn off the isolation tester and discharge the test voltage with a $10\text{ M}\Omega$ resistor between input and case.

10.4 AC isolation test input to output and input to case

Beware of the rather high capacitive earth currents (about 100mA) that will occur during this test.

1. Disconnect all cables from the converter.
2. Connect the output terminals of the converter to case. See *Figure 10*.
3. Connect the input terminals together.
4. Connect your isolation tester between input and case. See *Figure 10* Raise the voltage of the isolation tester from 0 to 2500 Va.c. The voltage should not be applied for more than one (1) minute or the Y capacitors might be damaged.
5. Turn off the isolation tester and discharge the test voltage with a $10\text{ M}\Omega$ resistor between input and case.

11 Trouble shooting

11.1 There is no or wrong output voltage

- 1 Check that the input fuse is not broken.
- 2 Check that the input voltage polarity is correct.
- 3 Check that the input voltage is within the specified limits.
- 4 The converter may be in current limit due to excessive output current or an external short-circuit on the output.
 - Measure the output voltage. If shows > 0.5 V the thyristor OVP, *see section 7.2*, might have triggered.
 - Disconnect the input by removing the fuse.
 - Disconnect the load.
 - Connect input fuse again and measure the output voltage. If the converter now starts, the load is too high or there is a short circuit on the load side.
 - If there is an external short-circuit, remove it.
 - If the load is too large decrease the load or consult your Polyamp dealer.
- 5 The unit is broken. Contact your Polyamp dealer.

11.2 The input fuse blows when the input is connected

- 1 Check that the input voltage polarity is correct.
- 2 Check that the input fuse is of time delay type and with correct current rating. See *Table 1 to 3*.
- 3 The unit is broken. Contact your Polyamp dealer.

11.3 The converter starts and stops repeatedly

All models have an over/under voltage protection, which shuts down the converter if the input voltage is not within specified limits:

- 1 The cables to the converter input may be under-sized, causing too high voltage drop in the supply cables.

2. Your supply does not have enough current capacity so the input voltage to the converter drops below specified limit.

11.4 Fault report

We do not recommend you to repair a faulty unit. All unit opened by customer will not be repaired under warranty.

Please use our RMA system from our webpage www.polyamp.com

Warranty

All Polyamp DC/DC converters are warranted against defective material and workmanship. This warranty is valid for 24 months from the date of delivery. We will repair or replace products which prove to be defective during the warranty period. The warranty is valid only if the converter is used within specification.

Please describe the conditions when the fault occurred and please return a faulty converter to:

Your local distributor or:

**SWITCH CRAFT S.A.
Bel Air 63
CH-2300 La Chaux-de-Fonds
Switzerland**

**Tel: +41 32 9678800
Fax: +41 32 9678809
e-mail: info@switchcraft.ch**

**Latest version of this manual
www.polyamp.com**

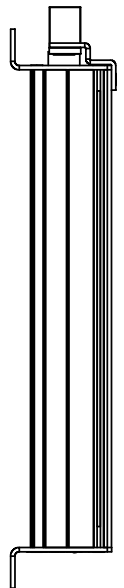
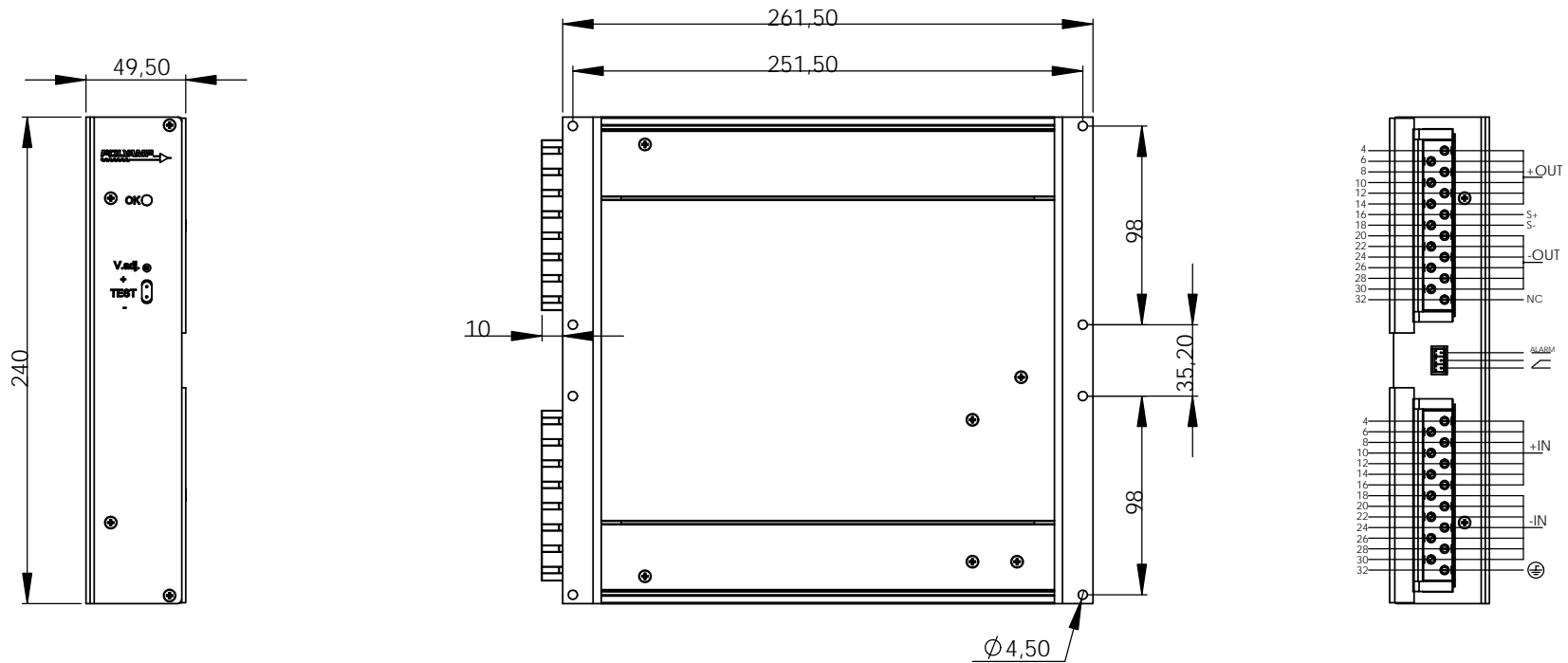

This document is the property of Polyamp AB and shall not, without the permission of Polyamp AB, be allowed, copied, used for manufacturing or communicated to any other person or company.

Weight (kg/m3)	Replaces dwg	Page 1(1)	Associated dwg No.	Units millimeters	Scale 1:2.5	Rev No 00	
	PSC600-800 Series Wall mounting H15 connector			Tolerances/Tolerances IS:ISO 2768-1 m Njennhet/Surf. text RA 6,3	Designer roand Approved by Rev by	Date (y/m/d) 140331 Date (y/m/d) - Date (y/m/d) -	
	Dwg No.					PSC600_001	

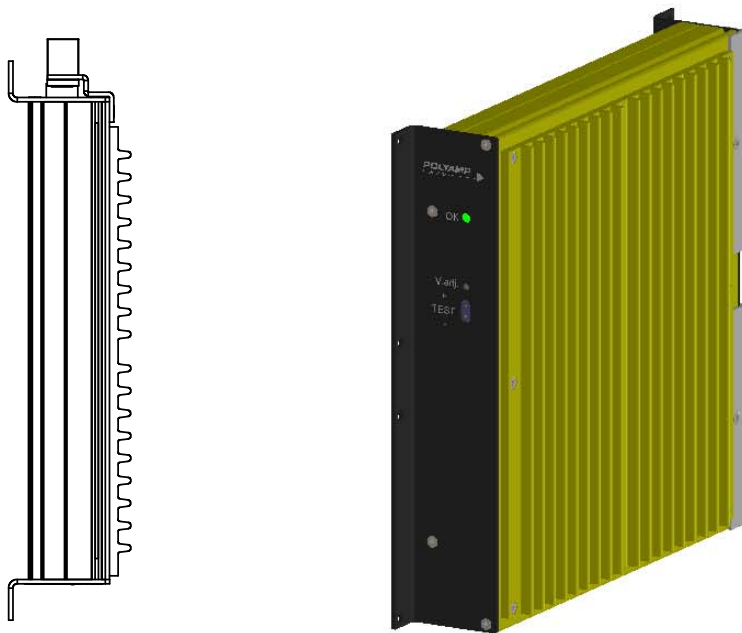
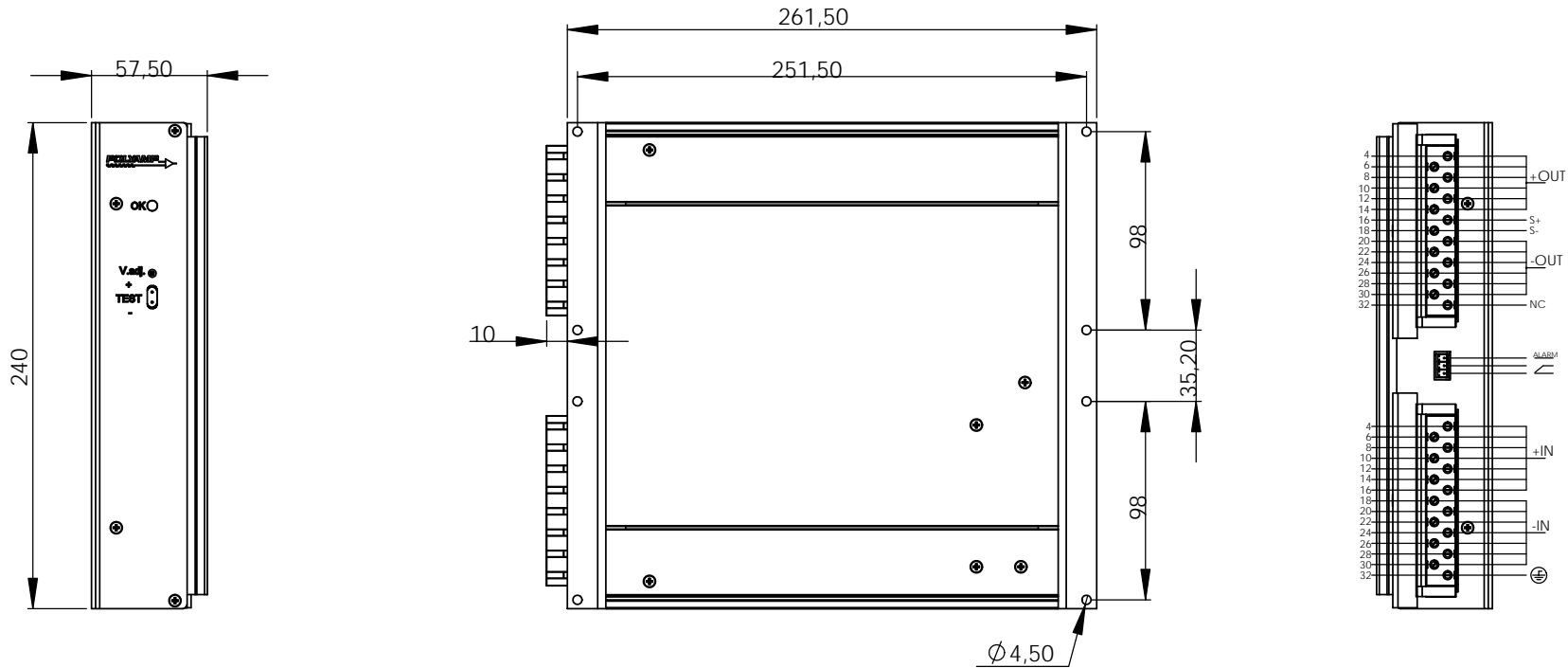

This document is the property of Polyamp AB and shall not, without the permission of Polyamp AB, be allowed, copied, used for manufacturing or communicated to any other person or company.

Weight (kg/m3)	Replaces dwg	Page 1(1)	Associated dwg No.	Units millimeters	Scale 1:2.5	Rev No 00
	PSC600-800 Series Wall mounting H15 connector 1 addon cooler		Tolerances/Tolerances ISIRI 7161.1 <i>m</i> Njennhet/Surf. test RA 6,3 Dwg No.	Designer roand Approved by Rev by	Date (y/m/d) Date (y/m/d) Date (y/m/d)	140331 Date (y/m/d) Date (y/m/d)
	PSC600_002					

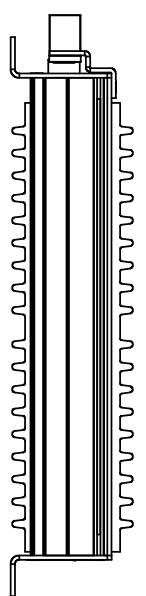
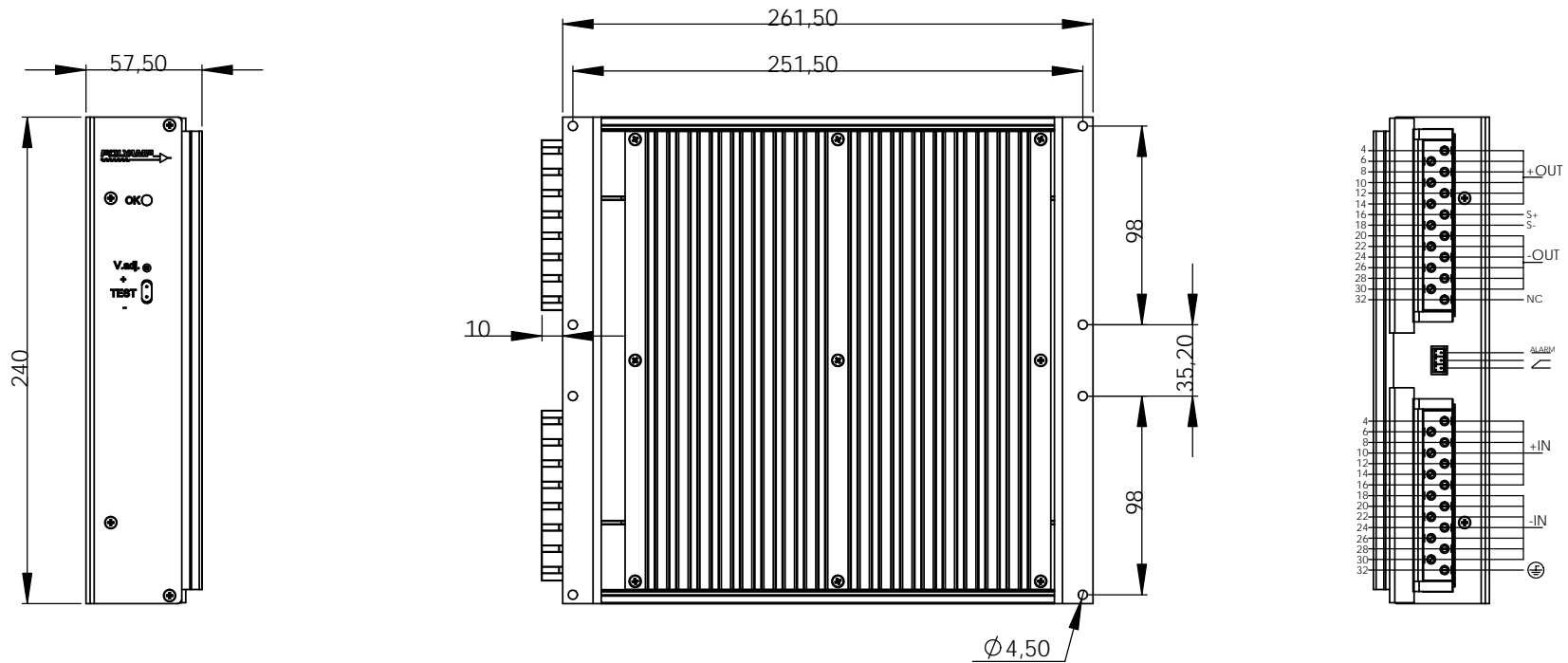

This document is the property of Polyamp AB and shall not, without the permission of Polyamp AB be allowed, copied, used for manufacturing or communicated to any other person or company.

Weight (kg/m)	Replaces dwg	Page 1(1)	Associated dwg No.	Units millimeters	Scale 1:2,5	Rev No 00
	PSC600-800 Series Wall mounting H15 connector 2 addon cooler		Toleranz/Tolerances ISO 2768-1 m Njennhet/Surf. text RA 6,3 Dwg No.	Designer roand Approved by Rev by	Date (y/m/d) Date (y/m/d) Date (y/m/d)	140331 Date (y/m/d) Date (y/m/d)
	PSC600_003					

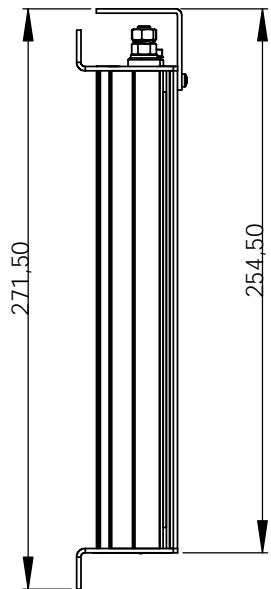
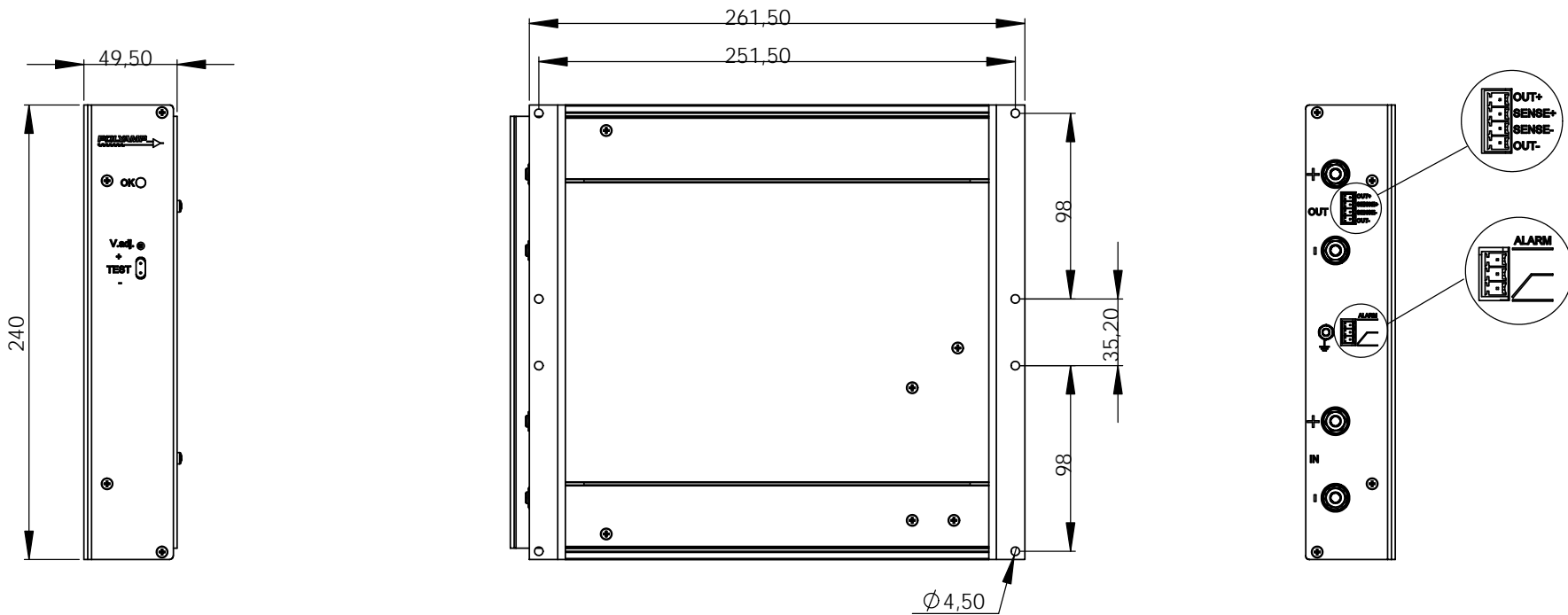

This document is the property of Polyamp AB and shall not, without the permission of Polyamp AB, be allowed, copied, used for manufacturing or communicated to any other person or company.

Weight (kg/m)	Replaces dwg	Page 1(1)	Associated dwg No.	Units millimeters	Scale 1:2.5	Rev No 00
	PSC600-800 Series Wall mounting Stud		Tolerance/Tolerances IS:ISO 2768-1	Designer roand	Date (y/m/d) 140331	
			Approved by	Date (y/m/d)		
			RA 6,3	Rev by	Date (y/m/d)	
			Dwg No.	PSC600_004		

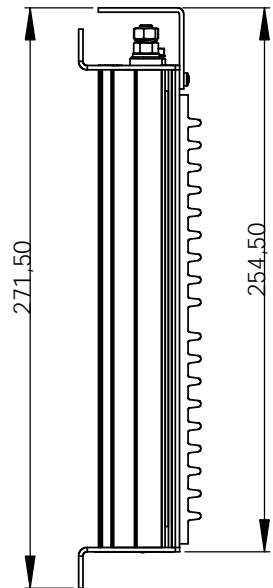
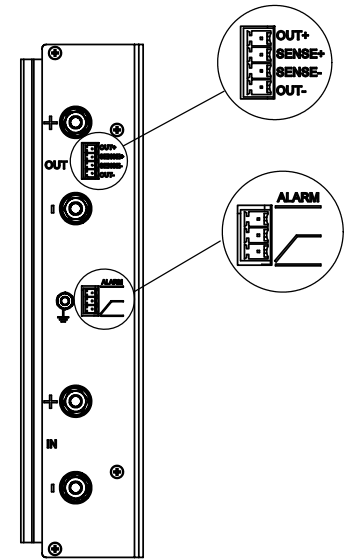
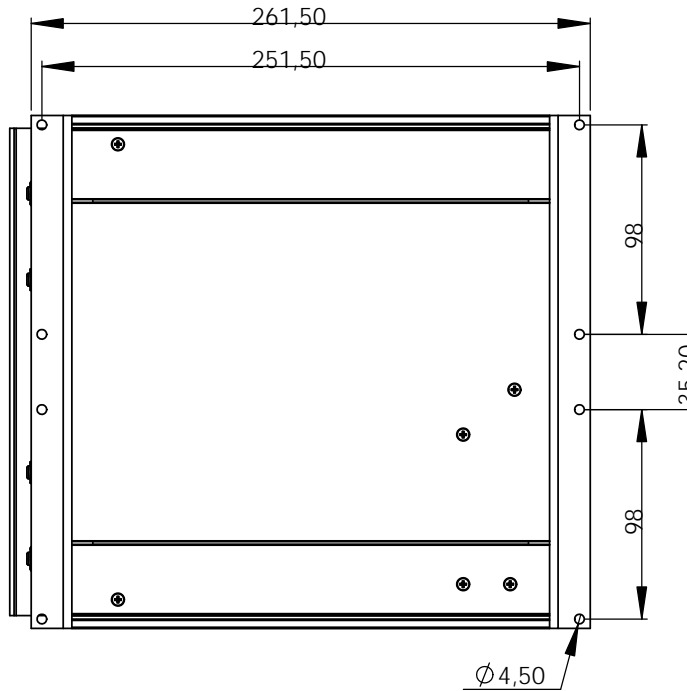
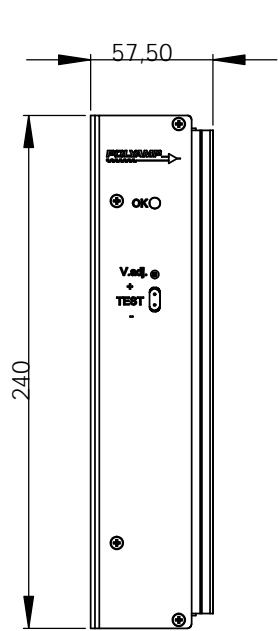

This document is the property of Polyamp AB and shall not, without the permission of Polyamp AB be allowed, copied, used for manufacturing or communicated to any other person or company.

Weight (kg/m3)	Replaces dwg	Page 1(1)	Associated dwg No.	Units millimeters	Scale 1:2.5	Rev No 00
	PSC600-800 Series Wall mounting Stud 1 addon cooler			Tolerance/Tolerances ISIRI 716:1	Designer roand	Date (y/m/d) 140331
				RA 6,3	Approved by	Date (y/m/d)
					Rev by	Date (y/m/d)
Dwg No.					PSC600_005	

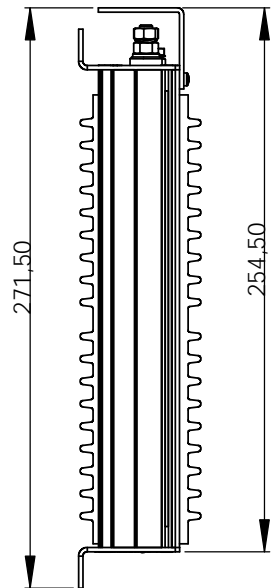
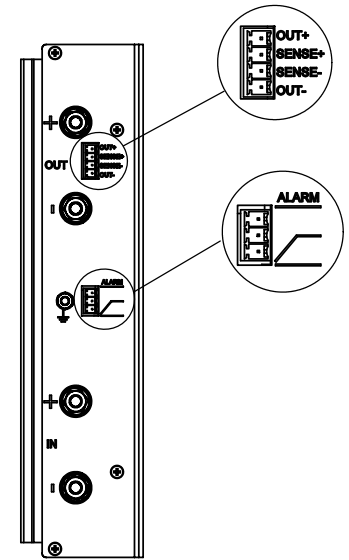
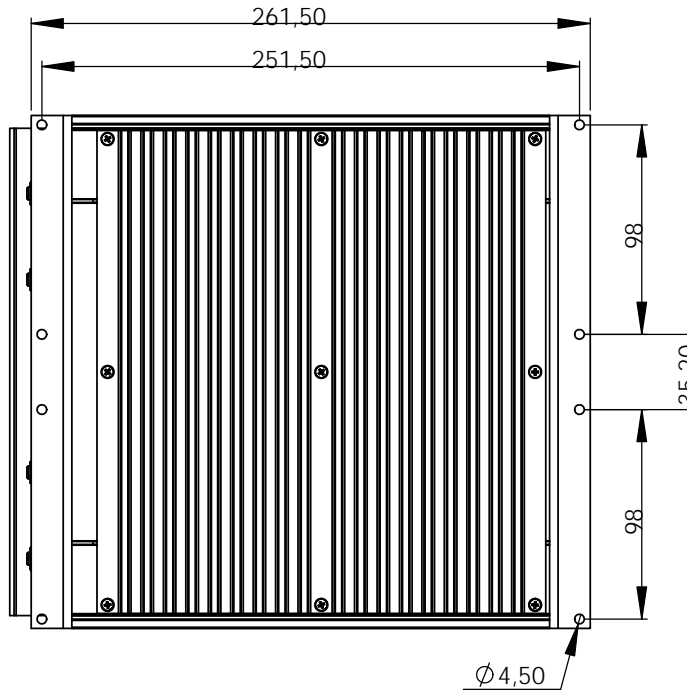
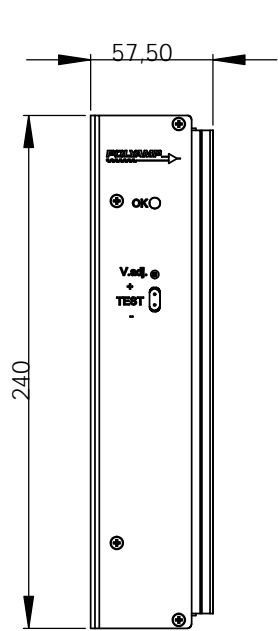

This document is the property of Polyamp AB and shall not, without the permission of Polyamp AB be allowed, copied, used for manufacturing or communicated to any other person or company.

Weight (kg/m ³)	Replaces dwg	Page 1(1)	Associated dwg No.	Units millimeters	Scale 1:2.5	Rev No 00	
	PSC600-800 Series Wall mounting Stud 2 addon cooler		Tolerances/Intolerances ISIRI 716:1 m Njennhet/Surf. test RA 6,3	Designer roand Approved by Rev by	Date (y/m/d) Date (y/m/d) Date (y/m/d)	140331 Date (y/m/d) Date (y/m/d)	
	Dwg No.					PSC600_006	

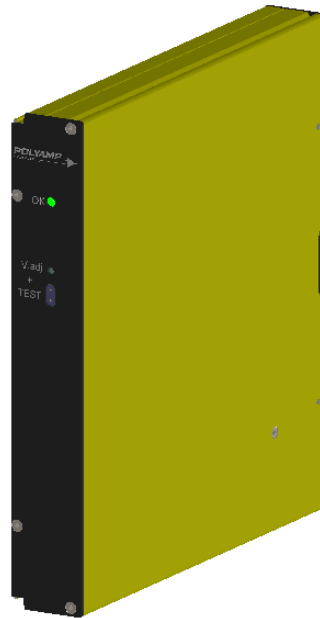
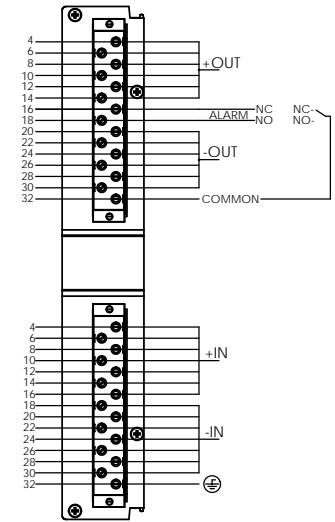
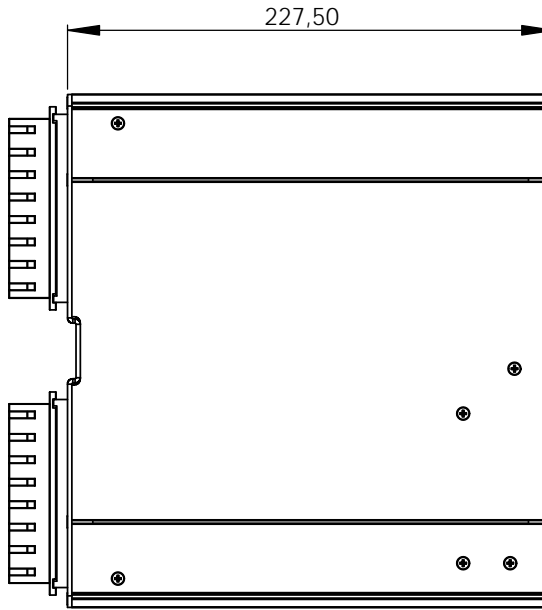
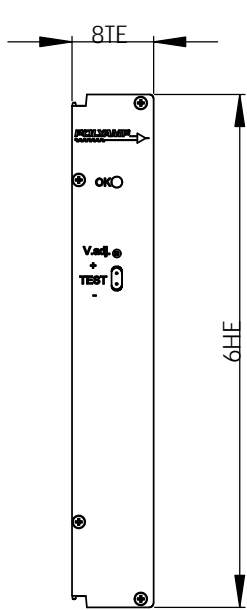

This document is the property of Polyamp AB and shall not, without the permission of Polyamp AB be allowed, copied, used for manufacturing or communicated to any other person or company.

Weight (kg/m3)	Replaces dwg	Page 1(1)	Associated dwg No.	Units millimeters	Scale 1:2.5	Rev No 00
	PSC600-800 Series Rack mounting 8TE H15 connector		Tolerances/Tolerances IS:ISO 2768:1 m Njmmhet/Surf. list RA 6,3 Dwg No.	Designer roand Approved by Rev by	Date (y/m/d) Date (y/m/d) Date (y/m/d)	140331 Date (y/m/d) Date (y/m/d)
	PSC600_007					

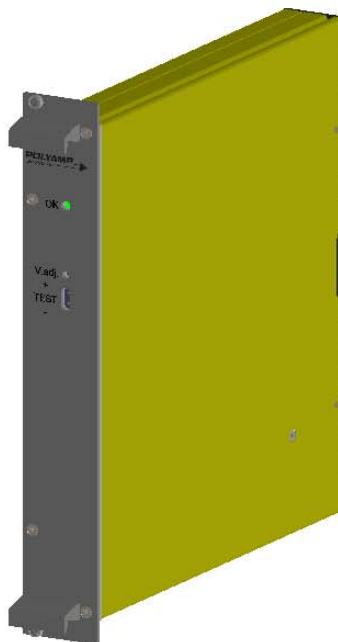
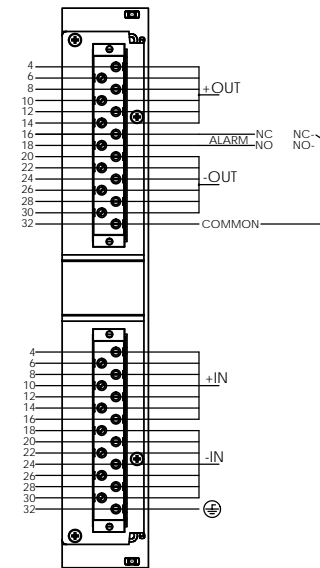
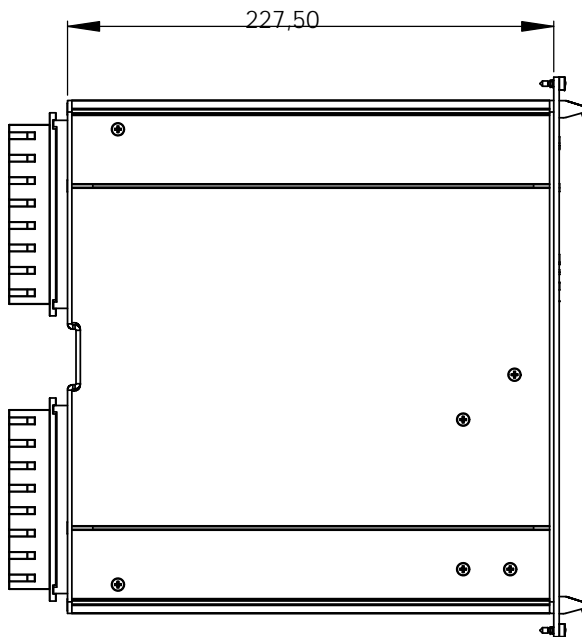
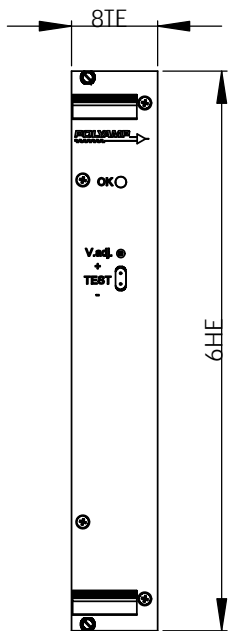

This document is the property of Polyamp AB and shall not, without the permission of Polyamp AB be allowed, copied, used for manufacturing or communicated to any other person or company.

Weight (kg/m3)	Replaces dwg	Page 1(1)	Associated dwg No	Units millimeters	Scale 1:2.5	Rev No 00
	PSC600-800 Series Rack mounting 8TE H15 connector			Tolerance/Tolerances ISO 2768-1	Designer roand	Date (y/m/d) 140331
				<i>m</i>	Approved by	Date (y/m/d)
				Uppermhet/Surf. text RA 6,3	Rev by	Date (y/m/d)
				Dwg No.	PSC600_008	

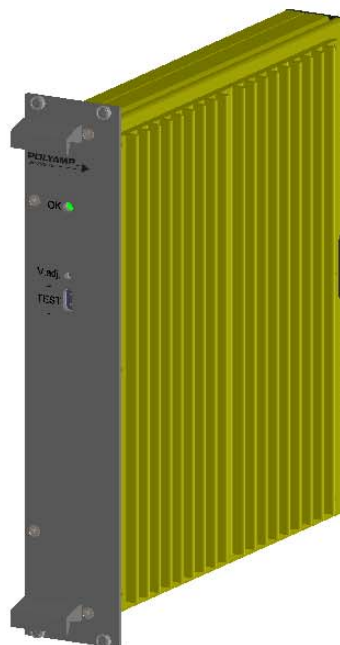
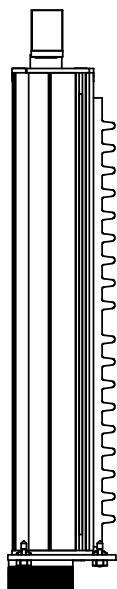
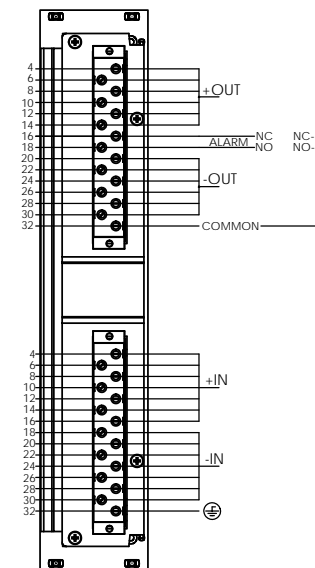
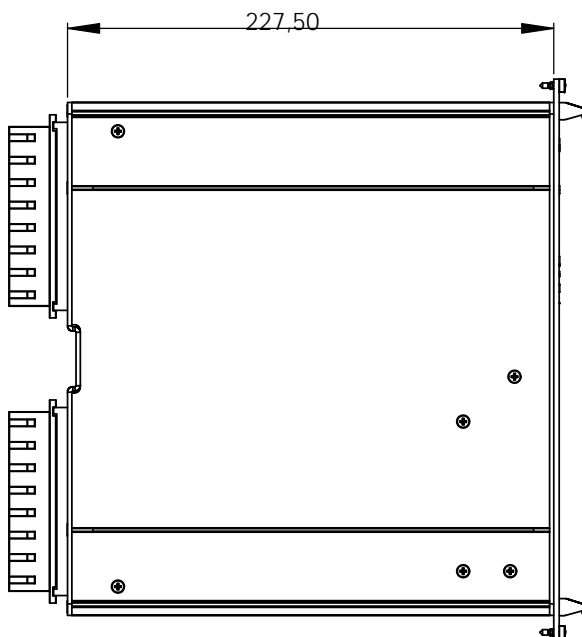
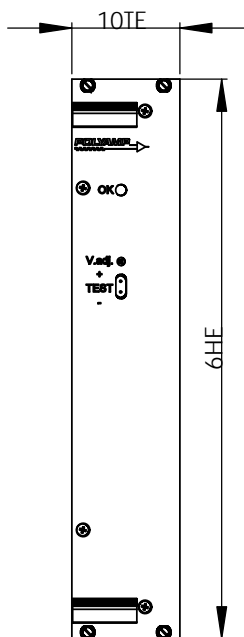

This document is the property of Polyamp AB and shall not, without the permission of Polyamp AB, be allowed, copied, used for manufacturing or communicated to any other person or company.

Weight (kg/m3)	Replaces drawing	Page 1(1)	Associated drawing No.	Units millimeters	Scale 1:2.5	Rev No 00
	PSC600-800 Series Rack mounting 10TE H15 connector 1 addon cooler			Tolerance/Tolerances ISO 2768-1	Designer roand	Date (y/m/d) 140331
				<i>m</i>	Approved by	Date (y/m/d)
				RA 6,3	Rev by	Date (y/m/d)
				Dwg No.	PSC600_009	

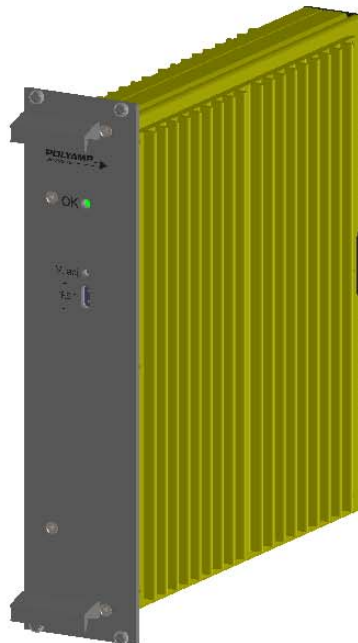
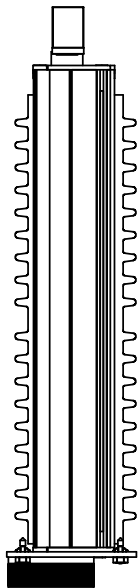
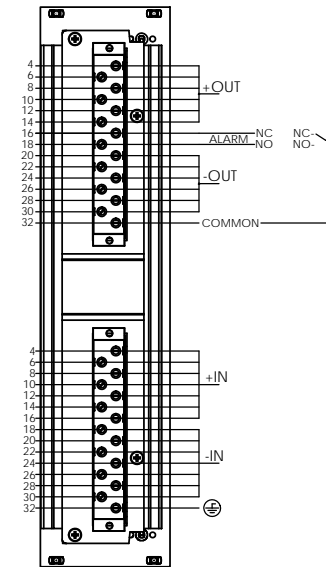
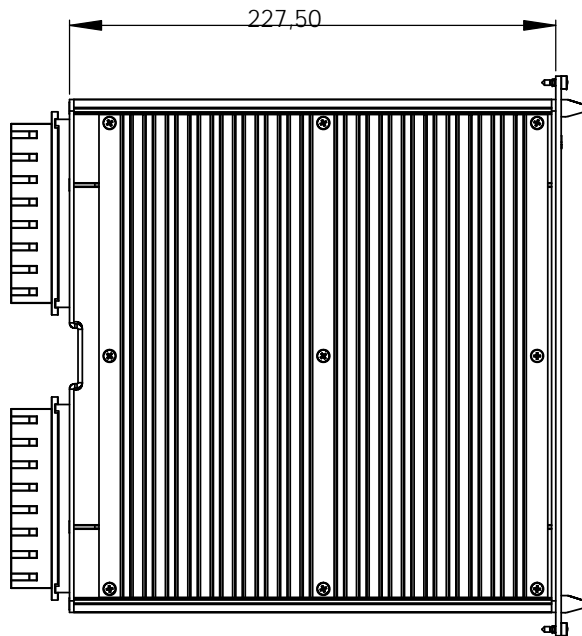
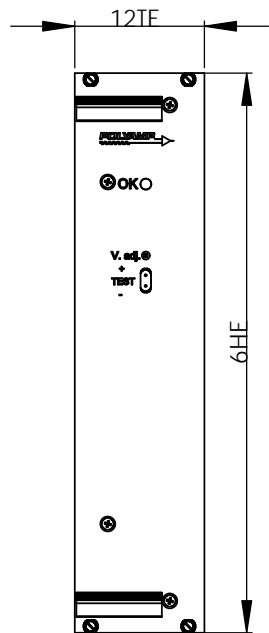

This document is the property of Polyamp AB and shall not, without the permission of Polyamp AB, be allowed, copied, used for manufacturing or communicated to any other person or company.

Weight (kg/m)	Replaces dwg	Page 1(1)	Associated dwg No.	Units millimeters	Scale 1:2.5	Rev No. 00
	PSC600-800 Series Rack mounting 12TE H15 connector 2 addon cooler			Tolerance/Tolerances ISO 2768-1	Designer roand	Date (y/m/d) 140331
				<i>m</i>	Approved by	Date (y/m/d)
				RA 6,3	Rev by	Date (y/m/d)
				Dwg No.	PSC600_010	

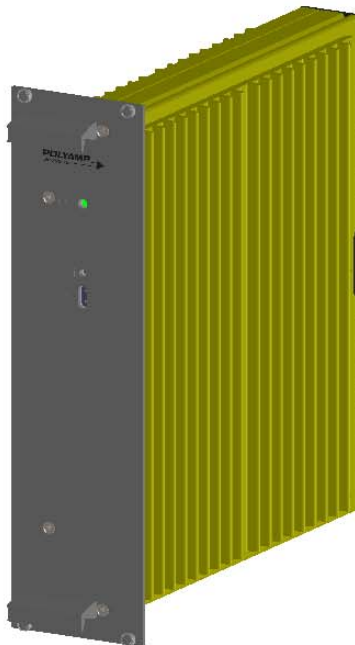
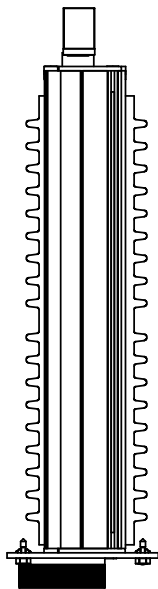
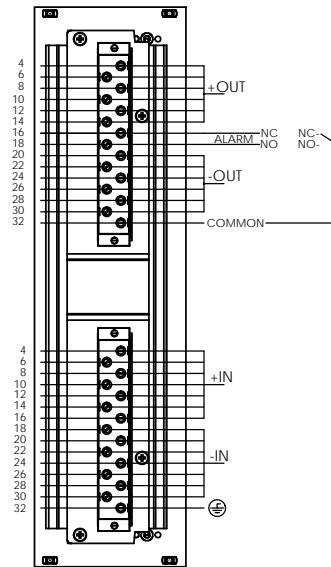
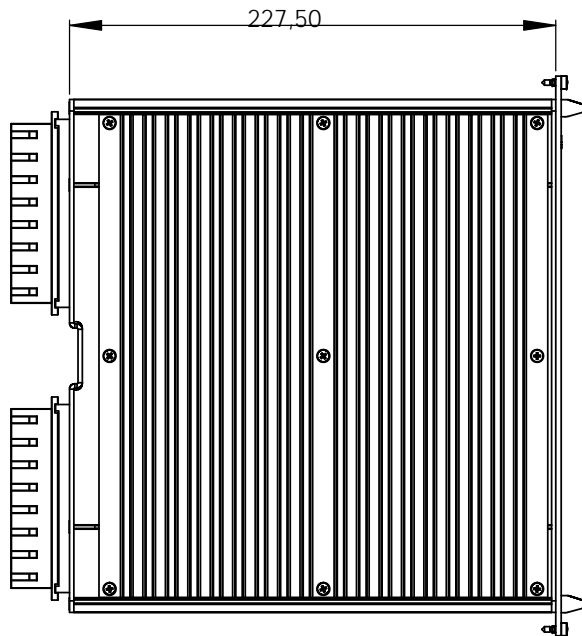
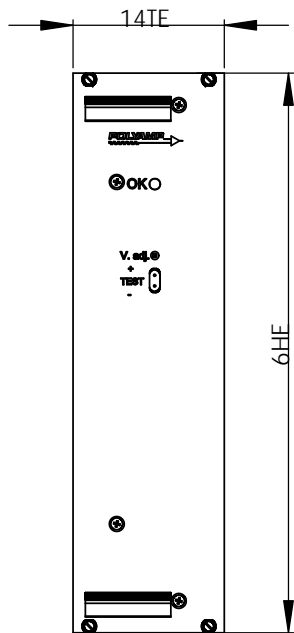

This document is the property of Polyamp AB and shall not, without the permission of Polyamp AB be allowed, copied, used for manufacturing or communicated to any other person or company.

Weight (kg/m3)	Replaces dwg	Page 1(1)	Associated dwg No.	Units millimeters	Scale 1:2.5	Rev No 00
		PSC600-800 Series Rack mounting 14TE H15 connector 2 addon cooler			Tolerances/Intolerances ISIRI 276:1 m Njennhet/Surf. list RA 6,3 Dwg No.	Designer roand Approved by Rev by Date (y/m/d) 140331 Date (y/m/d) Date (y/m/d)
						PSC600_011

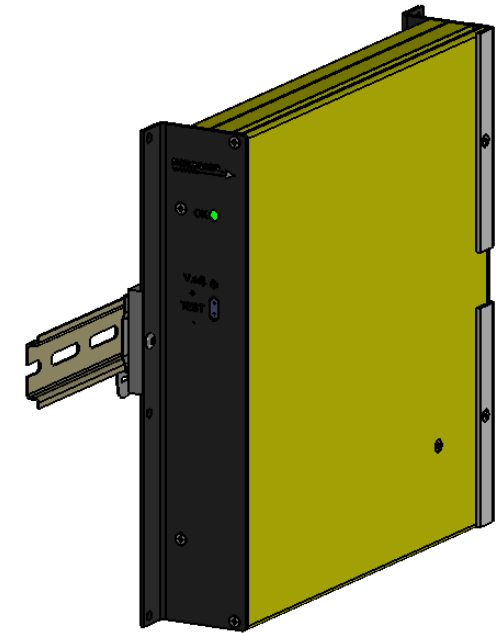
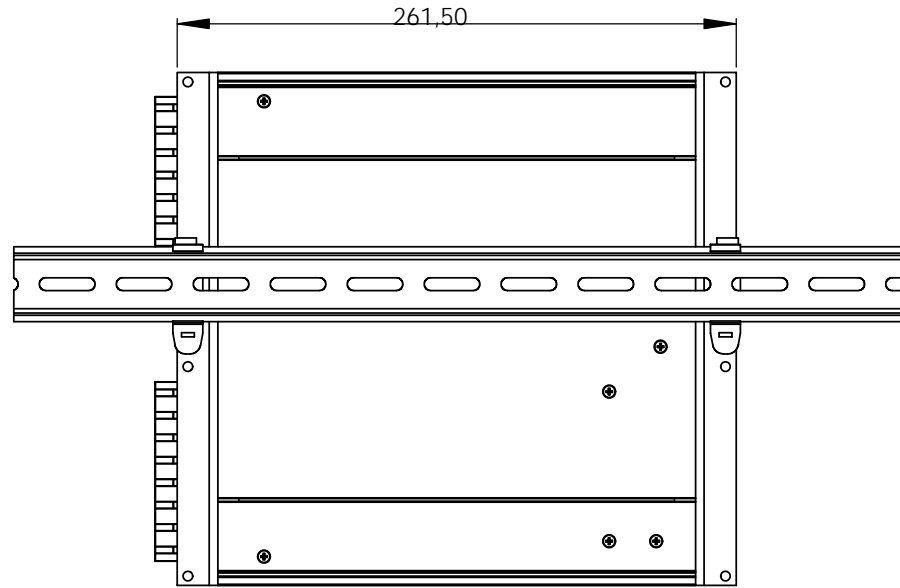
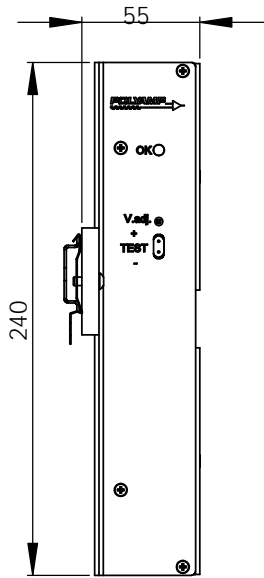

This document is the property of Polyamp AB and shall not, without the permission of Polyamp AB be allowed, copied, used for manufacturing or communicated to any other person or company.

Weight (kg/lb)	Replaces dwg	Page 1(1)	Associated dwg No.	Units millimeters	Scale 1:2.5	Rev No. 00
		PSC600-800 Series Wall mounting H15 connector DIN rail mounting			Tolerances/Intolerances ISIRI 7161.1 m RA 6,3	Designer roand Approved by Rev by Date (y/m/d) 150325 Date (y/m/d) Date (y/m/d)
					Dwg No. PSC600_18	