

# WPS500X

500 psi / 34.5 bar

## Automotive Pressure Transducer

This accessory complies with the following standards:

- Electromagnetic Compatibility (EMC) Directive 2004/108/EC
- FCC Part 15
- Pressure Equipment Directive 97/23/EC Article 3.3



## 1. Safety terms and symbols

### Appearing in this manual:

---



WARNING

WARNING statements identify conditions or practices that could result in injury or death.

---



CAUTION

CAUTION statements identify conditions or practices that could result in damage to this product or other property.

---

### Appearing on the product:

---



Danger of personal injury or property damage. Refer to manual for details.

---

## General safety summary

Please review the following safety precautions to avoid injury and prevent damage to this transducer or any equipment that is connected to it.

### **DO connect safely**

This transducer must be connected using only the pressure hoses and connectors supplied. Pico Technology cannot accept responsibility for damage or injury caused by the use of unsuitable pressure hoses or connectors.

### **DO follow the vehicle manufacturer's safety instructions**

This is particularly important when connecting the transducer to pressurized fuel lines.

### **DO ground the unit when working with fuels**

When working on or near fuel systems, you must connect the transducer to an electrical ground. If you are using the transducer with a PicoScope oscilloscope, connect a suitable lead from any unused BNC connector on the front panel of the scope to the ground of the vehicle.

### **DO wear appropriate personal protective equipment**

Wear appropriate personal protective equipment (PPE) when working with pressurized fluids.

**DO NOT exceed maximum working pressure**

To avoid injury, do not use the transducer with pressures above 500 psi / 34.5 bar.

**DO NOT exceed maximum temperature**

The lithium polymer (LiPo) battery inside the transducer can be damaged by excessive heating. Do not store or operate the unit at temperatures above 60 °C (140 °F).

**DO NOT operate without covers**

To avoid equipment damage and personal injury, do not operate this transducer with the covers removed.

**DO NOT operate in wet or damp conditions**

To avoid incorrect readings and possible equipment damage, do not operate this transducer in wet or damp conditions or submerge it in liquid. The transducer is splash-resistant but not immersion-proof.

**DO NOT operate in an explosive atmosphere**

To avoid personal injury and fire hazard, do not operate this transducer in an explosive atmosphere.

**DO NOT operate the transducer if damaged**

If you suspect there is damage to this transducer, have it inspected by qualified service personnel. Do not attempt to dismantle or repair it yourself.

**DO NOT use with damaged pressure hoses**

All the pressure hoses supplied by Pico Technology have been pressure-tested and must not be used if they have been disassembled or damaged.

**DO NOT use in long-term or permanent installations**

The WPS500X is intended for immediate diagnostic purposes and not long-term or permanent use. For example, it should not be connected to a race car as a monitoring system.

**DO NOT use on high pressure common-rail diesel fuel systems**

The high pressure from the mechanical fuel pump (usually found in the engine bay) cannot be measured using the WPS500X. However, the pressure from the electronic fuel pump (usually found close to the fuel tank) can be measured using the WPS500X.

## 2. Description

The WPS500X automotive diagnostic pressure transducer allows quick and accurate pressure analysis of many automotive systems. It can be used for many different pressure diagnostic applications, saving the need to own several transducers for several applications.

It offers these features:

- high resolution and accuracy
- auto-zeroing
- built-in zoom tool
- integrated bleed-off / pressure relief valve
- three pressure ranges

### 3. Re-ordering codes

If you need to re-order spare parts, please use the part numbers listed here.

#### WPS500X pressure transducer (PP652)

Part No	Qty	Description
TA071	1	WPS500X pressure transducer
TA081	1	USB to mini-USB charging cable
TA098	1	5 m (16-foot) BNC to BNC cable
DO157	1	WPS500X manual
MI220	1	Hard plastic carrying case

#### WPS500X pressure transducer kit (PP836)

Part No	Qty	Description
TA071	1	WPS500X pressure transducer
TA081	1	USB to mini-USB charging cable
TA083	1	Gasoline pressure fuel hose with large Schrader valve
TA085	1	Vacuum hose
TA086	1	Bleed hose
TA087	1	Exhaust adaptor
TA088	1	M14 high-strength compression hose with adapter for deep reach spark plugs
TA098	1	5 m (16-foot) BNC to BNC cable
TA103	1	M10 high-strength compression hose
TA105	1	Ford Triton compression hose
TA117	1	Gasoline pressure fuel hose with small Schrader valve
TA129	1	Universal vacuum adaptor
DO157	1	WPS500X manual
MI220	1	Hard plastic carrying case

#### Optional accessories

The following accessories are also available for purchase:

Part No	Description
TA104	M18 high-strength compression hose
TA142	Foster 2 Series quick coupler female to 1/8" MPT male for making custom hoses

#### O-rings

The following O-rings can be used as replacements on our compression hoses.:

Nominal code*	Description	Size	O-ring CSA	Material
AS568-011	Used on Compression Hose M10 (TA103)	OD 7/16" ID 5/16"	1/16"	Viton
AS568-013	Used on Compression Hose M14 (TA088)	OD 9/16" ID 7/16"	1/16"	Viton
AS568-015	Used on Compression Hose M18 (TA104)	OD 11/16" ID 9/16"	1/16"	Viton

\*Pico Technology does not stock these parts.

## 4. The parts of your WPS500X pressure transducer

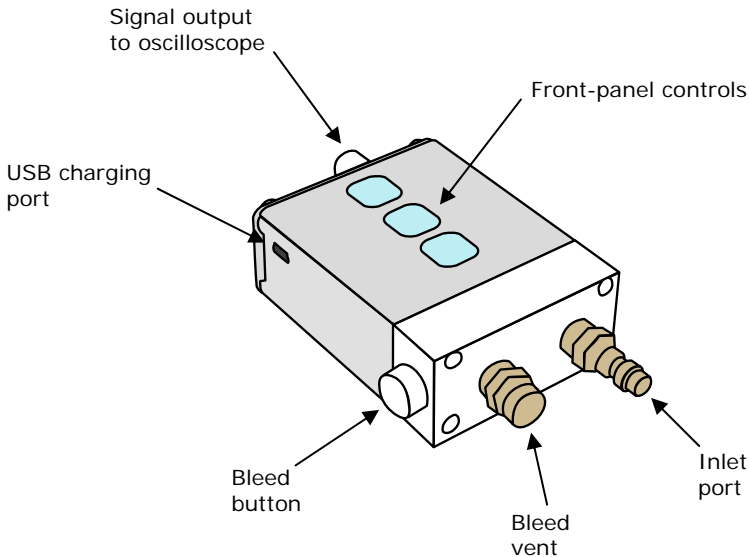

Signal output	Use the BNC-to-BNC cable supplied to connect this to your oscilloscope.
Front-panel controls	See Section 5.
USB charging port	For battery recharging only (no data connection). Connect to any USB port on a computer or a 5 volt USB wall charger.
Inlet port	Connect the pressure hose here.
Bleed vent	When the bleed screw is opened, this vent allows fluid to drain out of the measurement chamber.
Bleed button	Push to open the bleed vent. Some models have a screw instead of a push-button.

## 5. Front-panel controls

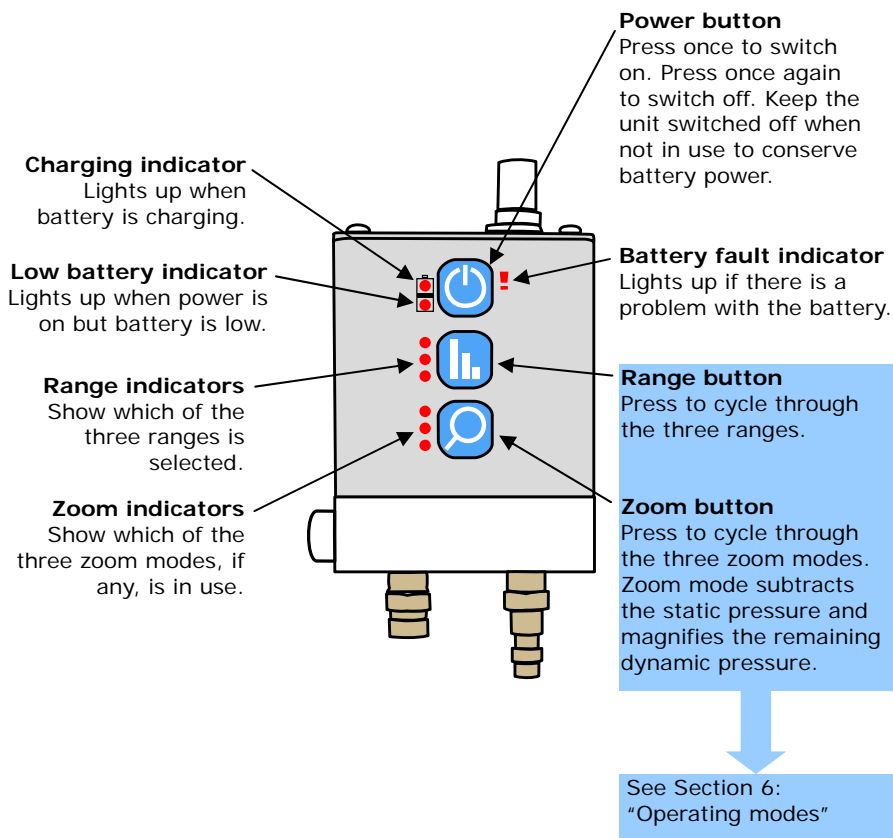



## 6. Operating modes

### Ranges 1 to 3

Select the range using the Range button shown in Section 5: "Front-panel controls".

**Range 1:** The first range measures from -15 psi (-1 bar) to +500 psi (34.5 bar). It offers high resolution and accuracy for high-pressure tests such as cranking and running cylinder compression or fuel pressure testing. It is also helpful for identifying cam timing issues such as jumped timing belts and stretch timing chains, especially on multi-cam engines that may not have a cam sensor on each camshaft. The WPS500X kit includes a specially designed compression hose for performing this test with a significantly reduced error and higher operating temperature range than conventional compression hoses and adapters.

**Range 2:** The second range measures from -15 psi (-1 bar) to +50 psi (+3.45 bar). This range is ideal for vacuum test and fuel system tests. When testing these systems the zoom function is especially useful to analyze valve operation with the vacuum waveform or the injectors through the fuel waveform.

**Range 3:** The third range measures -5 to +5 psi (-0.345 to +0.345 bar). This setting is sensitive enough to analyze small pressures or pulses such as exhaust pulses from the tail pipe.

### Zoom modes 1 to 3

The zoom feature operates by removing all of the voltage from the signal below 100 Hz and then magnifying the remaining signal. Select the zoom using the zoom button shown in Section 5: "Front-panel controls".

**Zoom 1:** This mode multiplies the signal 10 times.

**Zoom 2:** This mode multiplies the signal 100 times. For example, let's say the transducer is connected to intake manifold vacuum on a running engine at idle with the transducer set to mode 2 (-15 to +50 psi or -1 to +3.45 bar) and the waveform on the scope is at -9 psi (-0.6 bar). The fluctuation in the signal caused by the valves' opening and closing compared with atmospheric pressure forcing air into the manifold will be visible but will only make up a small portion of the overall signal. Selecting the zoom function will bring the waveform up to the zero line (remove the -9 psi portion) and the fluctuations will be magnified, making analysis of this component of the signal much clearer.

**Zoom 3:** Zoom level 3 multiplies the signal by about 1,000 times. It is extremely sensitive and is suitable only for vacuum measurements.

## 7. Preparation for use

### Compatible fluid types

The WPS500X is suitable for use with the following types of fluid:

- Low-pressure gasoline and diesel
- Engine oil
- Air

### Before first use

- Remove all packaging.
- Charge the internal battery. For instructions, see Section 9: "Maintenance".

## 8. Making a measurement

Making a pressure measurement involves the following steps. Each step is explained in more detail in the sections below.

- Prepare the transducer
- Measure pressure
- Release the pressure in the measurement chamber
- Clean the measurement chamber

### Preparing the transducer

- Ensure that the transducer's internal battery is charged.
- Unplug the charging cable from the transducer.
- Before switching on, disconnect any pressure source from the transducer. A pressure source left connected will interfere with the self-calibration procedure described below.
- Switch on the transducer and wait until the three Range LEDs light up in sequence. At the end of the sequence, Range 1 LED remains lit, showing that the transducer has finished its auto-zeroing procedure. The entire procedure should take less than 10 seconds.

### Measuring pressure

- If your WPS500X has a bleed screw, ensure that the bleed screw is firmly closed.
- Connect the appropriate pressure hose to the pressure sensing port.



WARNING

Use only pressure hoses and connectors supplied with the WPS500X or otherwise manufactured to an adequate standard. Pico Technology cannot accept responsibility for damage or injury caused by the use of unsuitable pressure hoses or connectors.

---



WARNING

Always check that the pressure hose is securely fastened to the transducer before pressurizing the system. Always check for leaks when connecting the unit and to never leave it connected to a vehicle unattended (especially when connected to fuel).

---

- If measuring liquid pressure, bleed any air out of the measurement chamber first.
- Use the BNC cable supplied to connect the output of the transducer to the input channel of the oscilloscope.
- Switch on the computer and run the PicoScope software.
- In the PicoScope software, select the "Automotive" menu and then the appropriate pressure test.
- Press the Range button on the transducer to select the desired measuring range.
- Start the vehicle's engine.
- A waveform showing the pressure of the system will appear on the PicoScope display.

## Releasing the pressure in the measurement chamber

After each measurement, some fluid will remain under pressure in the measurement chamber. Follow the instructions below to release the pressure.

- Hold the transducer over a suitable container to catch the fluid expelled from the bleed vent.

**WARNING**

The fluid released from the bleed vent may be under high pressure. Position the transducer so that the fluid released cannot cause damage or injury.

---

## Push-button units

Press the button to release the pressure from the chamber.

## Bleed-screw units

- **SLOWLY** loosen the bleed screw by turning it counter-clockwise. Do not remove the screw from the transducer.
- Allow the fluid to emerge from the bleed vent.
- When no more fluid emerges, tighten the bleed screw.

## Cleaning the measurement chamber

If you are measuring the pressure of a liquid, some of the liquid will remain in the measurement chamber after use. To prevent cross-contamination between liquids, or between liquids and air, you must clean the measurement chamber after use.

**WARNING**

**DISCONNECT** all pressure hoses from the transducer. **DO NOT** attempt to clean the measurement chamber when the unit is under pressure.

---

**CAUTION**

When disassembling the bleed valve for the first time, hold the transducer over an empty container in case any loose parts drop out.

---

- Dismantle the bleed valve and allow any liquid to drain out.

The bleed valve in your WPS500X pressure transducer may be either a ball valve, a needle valve or a Schrader valve, as shown in the drawings below.

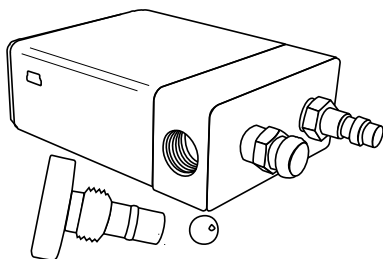

WPS500X with ball valve

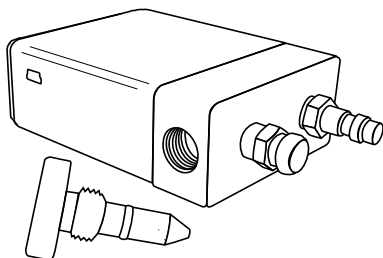

WPS500X with needle valve

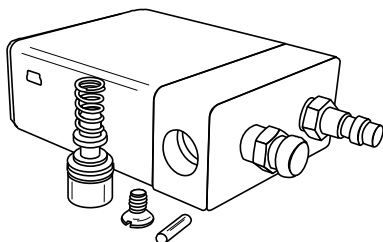

WPS500X with push-button valve

### Ball valve

- If the ball is still inside the ball valve, allow it to drop out. Clean and oil the ball with a non-hygroscopic oil that is compatible with steel and aluminum. Ordinary motor oil is suitable.
- If the ball needs replacing, see Section 9: "Maintenance".
- Clean the bleed screw. Flush out the measurement chamber with brake cleaner if necessary, then replace the ball and the bleed screw.

### Needle valve

- Clean the bleed screw. Flush out the measurement chamber with brake cleaner if necessary, then replace the bleed screw.

### Push-button valve

- Remove the countersunk screw from the back of the transducer near the push-button.
- Hold the transducer upside-down with the screw hole facing down.
- Prepare to catch the retaining pin that will drop out of the hole in the next step.
- Depress the push-button until the retaining pin drops out.
- Withdraw the push-button assembly, including the spring.
- Clean the valve parts, spring, retaining pin and screw with brake cleaner.
- Flush out the measurement chamber with brake cleaner. Push in the centre of the Schrader valve, visible at the bottom of the push-button hole, to allow the cleaner to flow through.
- Replace the push-button, retaining pin and screw. When replacing the screw, take care not to allow any grit into the mechanism. The screw should be hand-tight.

## 9. Maintenance

### Cleaning the housing

Clean the transducer's housing by wiping it with a rag moistened with clean water or water-based detergent. Allow the housing to dry before use.

- Do not use fuel or any other solvent
- Do not use abrasive cleaning agents
- Do not submerge the unit in any liquid
- Do not dismantle the unit
- Do not use the unit until it is perfectly dry.

### Cleaning the measurement chamber

See Section 8 above.

### Recharging the internal battery

- To charge using a computer, switch on the computer and allow it to boot. Disable any power-saving modes to ensure that the computer does not switch off before recharging is complete. Connect the transducer to the USB port of the computer using the USB charging cable provided.
- To charge using a USB wall charger, connect the transducer to the charger using the USB charging cable provided.
- Leave the transducer to charge for 5 hours.
- Unplug the USB cable from the transducer before use. Leaving the cable plugged in may affect measurement accuracy.

### Repairs

If the unit is damaged or stops working, return it to Pico Technology or an authorized Pico distributor for repair. Do not attempt to dismantle or repair the unit.

### Replacing the bleed valve ball (if fitted)

If the ball in the bleed valve is lost, it can be replaced with a standard 0.25 inch (6.35 mm) steel bearing ball. To re-seat the ball, clean the port and then seat the ball using a brass drift.

### Disposal

The WPS500X contains a lithium polymer (LiPo) battery. When the transducer reaches the end of its life, take the entire unit to a battery recycling facility.



WARNING

**YOU MUST** observe the instructions below. Incorrect disposal of the battery could cause a fire or an explosion.

- 
- Do not open the unit to remove the battery
  - Do not crush or shred the unit
  - Do not dispose of in fire

## 10. Specifications

Inlet			
Pressure ranges	Range 1	Range 2	Range 3
		-15 to +500 psi -1 to +34.5 bar	-15 to +50 psi -1 to +3.45 bar
Connector	Male push-fit		
Output			
Scaling	1 V/100 psi (6.89 bar)	1 V/10 psi (0.689 bar)	1 V/1 psi (0.0689 bar)
Offset (typical)	Auto-zeroing		
Connector	BNC female, fits Pico Technology cable TA098		
Performance			
Accuracy	1% of scale	1% of scale	5% of scale
Response time (10% to 90%)	100 $\mu$ s	100 $\mu$ s	filtered
Power supply			
Type	Built-in LiPo battery, not user-serviceable		
Charging current	500 mA (max.) at 4.75 V to 5.25 V from USB charger cable		
Charging connector	USB mini, fits Pico Technology cable TA081		
Ambient operating temperature	0 to 60 °C (32 to 140 °F) max.		
Ambient storage temperature	0 to 60 °C (32 to 140 °F) max.		
Environmental protection	Splash-resistant against water, gasoline and diesel. Not immersion-proof.		
Weight	332 g (11.7 oz)		
Dimensions	133 x 74 x 30 mm (5.2 x 2.9 x 1.2 in.)		

## 11. Conversion factors

The SI unit of pressure and vacuum is the pascal, symbol Pa. These are some other units in common use:

1 bar	100 000 Pa
1 psi (pound per square inch)	$\approx$ 6 895 Pa
1 inHg (inch of mercury)	$\approx$ 3 386 Pa
1 inH <sub>2</sub> O (inch of water)	$\approx$ 250 Pa
1 mmH <sub>2</sub> O (millimeter of water)	$\approx$ 10 Pa

## Issue history:

- 1) 1.6.09 First issue.
- 2) 14.7.09 Corrections to power LED description, etc.
- 3) 21.9.09 Added FCC statement, needle-valve version.
- 4) 26.4.10 Removed kit. Added accessories list. Mentioned brake cleaner for flushing.
- 5) 6.7.10 Added push-button valve, temperature lower limits.
- 6) 17.2.12 -Refs to hydraulic fluids +PP836 contents list +Low-pressure fuel only.
- 7) 14.05.12 O rings information added.

## riešenia na presné meranie™

Elso Philips Service; tel: +421 32 6582410  
email: [elso@elso.sk](mailto:elso@elso.sk); web: [www.elso.sk](http://www.elso.sk)

Pico Technology  
James House  
Colmworth Business Park  
St. Neots  
PE19 8YP  
United Kingdom

[www.picoauto.com](http://www.picoauto.com)

This device complies with part 15 of the FCC Rules. Operation is subject to the following two conditions: (1) This device may not cause harmful interference, and (2) this device must accept any interference received, including interference that may cause undesired operation.

Pico Technology is a registered trademark of Pico Technology Ltd.



Manufactured in the United States



Copyright © Pico Technology Ltd. 2009-2012