



SM15K-series

- **SM 500-CP-90**
- **SM 1500-CP-30**

Firmware Update

It is strongly recommended, first to perform a firmware update before further operation.

See chapter Quick Start, paragraph 2.

QUICK START GUIDE

Contents:

- 1a - Safety Instructions
- 1b - Sicherheitsanweisungen
- 2 - Quick Start
- 3 - EC Declaration of Conformity

2a SAFETY INSTRUCTIONS - SM15K-series

1 Caution

The following safety precautions must be observed during all phases of operation, service and repair of this equipment. Failure to comply with the safety precautions or warnings in this document violates safety standards of design, manufacture and intended use of this equipment and may impair the built-in protections. Delta Elektronika shall not be liable for user's failure to comply with these requirements.

2 Installation Category

The Delta Elektronika power supplies have been evaluated to installation category II (Over voltage category II).

3 Grounding of Mains Terminals (AC Power Terminals)

This product is a safety Class 1 unit. To minimize shock hazard, the unit must be connected to the AC Power Supply mains through a four conductor power cable, with the ground wire firmly connected to an electrical ground (safety ground) at the power outlet.

For units designed to be hard-wired to the mains supply, the protective earth terminal must be connected to the safety electrical ground before another connection is made. Any interruption of the protective ground conductor, or disconnection of the protective earth terminal will cause a potential shock hazard that might cause personal injury.

4 Grounding of DC Power Terminals

If the DC power terminal of a unit is specified to sink or source to a maximum of 60VDC, and either the negative or positive DC power terminal is grounded, the voltage on the DC power terminals and sense connections can be considered safe.

Warning:

When the positive DC power terminal can exceed 60VDC in respect to the negative DC power terminal, additional external measures must be taken to ensure safety isolation of the DC power terminals and sense connections.

Warning:

When the negative power output of the unit can exceed 60VDC / 42.4Vpk in respect to ground, additional external measures must be taken to ensure safety isolation of the DC power terminals and sense connections.

The standard LAN, USB and Interlock connectors and optional interfaces are at ground level and can be considered safe if the negative DC power terminal of the unit does not exceed 1000VDC / 707Vpk in respect to ground.

Caution 1: If a low voltage unit has both DC power terminals floating, or if the DC terminals are in series with an external high AC or DC voltage, the lower DC power terminal can exceed the safe value in respect to ground as specified in the above warning!

Caution 2: Although a high voltage unit is set to a safe voltage below 60VDC, for safety it must always be considered as a high voltage unit! Wrong operation, a programming error or an external defect can result in an unsafe high DC output voltage.

For more information and schematics regards Grounding and Safety, see the special application note "*Safe operation of a power supply*" on the Delta Elektronika website.

5 Danger of electrical shock

Touching the contacts of the mains plug or wires directly after disconnecting from the mains can cause an electrical shock. See next paragraph "Connection to the mains supply".

6 Connection to mains supply

Either connect to the mains supply permanently or via an industrial type plug, complying with IEC 60309. "Permanently connected equipment" or "Pluggable equipment type B".

7 Fuses

Fuses must be changed by authorized Delta Elektronika service personnel only, for continued protection against risk of fire.

8 AC Input Ratings

Do not use an AC Supply which exceeds the AC input voltage and frequency rating of this unit. The AC input voltage and frequency rating of the Delta Elektronika power supply series are stated in the accompanying datasheet.

9 Live Circuits

Operating personnel should not remove the unit covers. No internal adjustment or component replacement is allowed by non Delta Elektronika qualified personnel. Never replace components with the power cable connected. To avoid injuries, always disconnect power, remove external voltage sources and discharge circuits before touching components.

10 Parts Substitutions & Modifications

Parts substitutions and modifications are allowed by authorized Delta Elektronika service personnel only. For repairs or modifications the unit must be returned to a Delta Elektronika service facility.

11 Removal of (safety) covers

Safety cover(s) are used to cover potentially hazardous voltages. Observe the following when removing safety cover(s):

- Switch off the unit.
- Disconnect the unit from the mains supply or power outlet.
- Wait for 5 minutes to allow internal capacitors to discharge.
- Unscrew the screws and remove the cover(s).
- Always place the cover(s) back before connecting the unit to the mains supply again.

12 Environmental Conditions

The Delta Elektronika power supplies safety approval applies to the following operating conditions:

- Indoor use
- Ambient temperature : -20 to 50 °C
- Maximum relative humidity : 95%, non condensing, up to 40 °C
: 75%, non condensing, up to 50 °C
- Altitude : up to 2000 m
- Pollution degree : 2



Caution risk of electrical Shock



Instruction manual symbol. The unit will be marked with this symbol when it is necessary for the user to refer to the instruction manual



Protective ground conductor terminal



Off (supply)



On (supply)

WEEE (Waste Electrical & Electronic Equipment)

1 Correct Disposal of this Product

Applicable in the European Union.



This marking shown on the product, its packing or its literature indicates that it should not be disposed with other wastes at the end of its working life, but should be collected separately to recycle it responsibly to promote the sustainable reuse of material resources.

2b SICHERHEITSANWEISUNGEN - SM15K-series

1) Vorsicht

Die folgenden Sicherheitsvorkehrungen müssen in allen Betriebs-, Service- und Reparaturphasen dieses Geräts befolgt werden. Die Nichteinhaltung der Sicherheitsvorkehrungen oder Warnungen in diesem Dokument verstößt gegen die Sicherheitsstandards im Hinblick auf Bauart, Produktion und vorgesehene Nutzung dieses Geräts und kann die eingebauten Schutzvorrichtungen beschädigen. Delta Elektronika haftet nicht dafür, wenn der Nutzer diesen Anforderungen nicht nachkommt.

2) Installationskategorie

Die Stromversorgungen von Delta Elektronika wurden der Installationskategorie II (Überspannungskategorie II) zugeordnet.

3) Erdung der Netzanschlussklemmen (AC-Einspeiseklemmen)

Dieses Produkt ist ein Gerät der Sicherheitsklasse 1. Um die Gefahr eines elektrischen Schlags zu minimieren, muss das Gerät mit einem Vierleiter-Stromkabel mit dem AC-Stromversorgungsnetz verbunden werden. Hierbei muss der Schutzleiter fest mit einem elektrischen Erdungsanschluss (Schutzleiter) an der Stromquelle verbunden sein. Bei Geräten, die fest mit dem Versorgungsnetz verdrahtet werden, muss die Schutzerdungsklemme mit dem Sicherheitserdungsanschluss verbunden werden, bevor eine andere Verbindung hergestellt wird. Eine Unterbrechung des Schutzleiters oder eine Trennung der Schutzerdungsklemme kann zu einem elektrischen Schlag führen, der zur Verletzung von Personen führen kann.

4) Erdung der DC-Einspeiseklemmen

Wenn die DC-Einspeiseklemme eines Geräts dafür ausgelegt ist, maximal 60 VDC zu empfangen oder zu beziehen und entweder die negative oder positive DC-Einspeiseklemme geerdet ist, können die Spannung auf den DC-Einspeiseklemmen und Sense-Verbindungen als sicher angesehen werden.

Warnung:

Wenn die positive DC-Einspeiseklemme im Verhältnis zur negativen DC-Einspeiseklemme 60 VDC überschreiten kann, müssen zusätzliche externe Maßnahmen ergriffen werden, um die Sicherheitsisolation der DC-Einspeiseklemmen und Sense-Verbindungen sicherzustellen.

Warnung:

Wenn die negative Leistung des Geräts im Verhältnis zur Erdung 60 VDC/42,4 Vpk überschreiten kann, müssen zusätzliche externe Maßnahmen ergriffen werden, um die Sicherheitsisolation der DC-Einspeiseklemmen und Sense-Verbindungen sicherzustellen.

Die standardmäßigen LAN-, USB- und Interlock-Verbindungen sowie optionale Schnittstellen sind geerdet und können als sicher angesehen werden, wenn die negative DC-Einspeiseklemme des Geräts im Verhältnis zur Erdung 1000 VDC/707 Vpk nicht überschreitet.

Vorsicht 1: Falls beide DC-Einspeiseklemmen eines Niederspannungsgerätes potentialfrei sind oder falls die DC-Klemmen in Reihe mit einer externen AC- oder DC-Hochspannung geschaltet sind, kann die niedrigere DC-Einspeiseklemme den sicheren Wert in Bezug auf die Erdung wie in der Warnung oben spezifiziert überschreiten.

Vorsicht 2: Obwohl ein Hochspannungsgerät mit einer sicheren Spannung unter 60 VDC betrieben wird, muss es zur Sicherheit immer als Hochspannungsgerät angesehen werden! Falsche Bedienung, ein Programmierfehler oder ein externer Fehler können zu einer unsicheren, hohen DC-Ausgangsspannung führen. Für weitere Informationen und Schaltpläne hinsichtlich Erdung und Sicherheit, siehe den speziellen Applikationshinweis „Safe operation of a power supply“ auf der Delta Elektronika-Webseite.

5) Gefahr eines elektrischen Schlags

Das Berühren der Kontakte des Netzsteckers oder der Kabel direkt nach der Trennung vom Netz kann zu einem elektrischen Schlag führen. Siehe nächster Paragraph „Verbindung mit dem Versorgungsnetz“.

6) Verbindung mit dem Versorgungsnetz

Entweder permanent mit dem Versorgungsnetz verbinden oder via einer Industriesteckverbindung entsprechend IEC 60309. „Permanent verbundene Ausrüstung“ oder „Steckbare Ausrüstung Typ B“.

7) Sicherungen

Sicherungen dürfen ausschließlich von autorisiertem Delta Elektronika-Service-Personal ausgetauscht werden, um Brandgefahr dauerhaft auszuschließen.

8) AC-Eingangssleistung

Verwenden Sie keine AC-Versorgung, welche die AC-Eingangsspannung und Frequenzleistung dieses Geräts überschreitet. Die AC-Eingangsspannung und Frequenzleistung der Delta Elektronika-Stromversorgungsserie sind im beiliegenden Datenblatt angegeben.

9) Aktive Stromkreise

Bedienungspersonal darf die Geräteabdeckungen nicht entfernen. Interne Einstellungen oder Bauteilaustausche sind ausschließlich qualifiziertem Personal von Delta Elektronika gestattet. Bauteile nie bei eingestecktem Stromkabel austauschen. Um Verletzungen zu vermeiden, vor dem Berühren von Bauteilen immer den Strom trennen, externe Spannungsquellen entfernen und Stromkreise entladen.

10) Teileaustausch & Modifikationen

Teileaustausch und Modifikationen sind ausschließlich autorisiertem Delta Elektronika-Service-Personal gestattet. Reparaturen oder Modifikationen am Gerät dürfen nur durch eine Delta Elektronika-Serviceeinrichtung durchgeführt werden.

11) Entfernung von (Sicherheits-) Abdeckungen

Sicherheitsabdeckung(en) werden verwendet, um potenziell gefährliche Spannungen abzudecken. Beachten Sie Folgendes, wenn Sie die Sicherheitsabdeckung(en) entfernen:

- Gerät ausschalten.
- Gerät von dem Versorgungsnetz oder der Stromquelle trennen.
- Warten Sie 5 Minuten, damit interne Kondensatoren sich entladen können.
- Schrauben abschrauben und Abdeckung(en) entfernen.
- Bevor Sie das Gerät wieder mit dem Versorgungsnetz verbinden, montieren Sie vorher jedes Mal die Abdeckung(en).

12) Umgebungsbedingungen

Die Stromversorgungssicherheitszulassung von Delta Elektronika gilt für die folgenden Betriebsbedingungen:

- Innengebrauch
- Umgebungstemperatur : -20 bis 50 °C
- Maximale relative Luftfeuchtigkeit : 95 %, nicht kondensierend, bis zu 40 °C
: 75 %, nicht kondensierend, bis zu 50 °C
- Höhe : bis zu 2000 m
- Verschmutzungsgrad : 2

3 QUICK START - SM15K-series

1 Connecting the unit

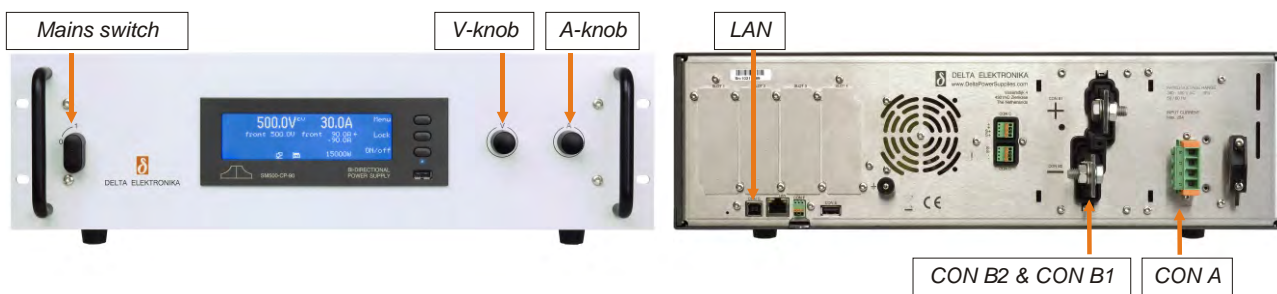

fig. 3 - 1

Warning! Never make connections to the Power Inputs, Power Outputs or Sense Connector when the unit is connected to the mains supply or power outlet! Safety covers are used to cover these in- and outputs.

Carefully read the chapter "Safety Instructions" in this manual before connecting or operating the unit!

Warning! Some components inside the power supply are at AC voltage even when the On/Off switch is in the off position. Therefore a readily accessible, appropriately rated, disconnect device shall be incorporated external to the equipment. The power supply shall be connected to the mains supply via a protection device with a rating of maximum 30A. For example a circuit breaker or fuses etc.

AC POWER TERMINALS (AC-MAINS)

- This connector is located at the rear side, marked as CON A.
- Use a cable with a diameter of 4 mm² for each wire and a sufficient voltage rating for the AC input voltage of the unit.
- Use the included 4-pole header with the markings L1, L2, L3, PE for connecting the wire to the unit (see fig. 3 - 1). The mounting torque for the header terminals is 0.6 Nm.
- Always connect the PE terminal to the Protective Earth, no neutral connection is required.
- The unit can operate only on a 3 phase grid, with a rated voltage of 380...480VAC.
- After installation, connect the pull relief and add the safety cover over the AC terminals.

DC POWER TERMINALS

- These terminals are located at the rear side, marked as CON B1 (PLUS) and CON B2 (MINUS), see fig. 3 - 1.
- For an SM500-CP-90 use a cable with a diameter of 35mm² and a mounting torque of 20Nm. Use cables with a sufficient voltage rating for the maximum output voltage of the unit.
- With high output current, use low resistive connections between the power supply and the load:
 - Mount the cable lugs directly on the DC power strips followed by a washer, a split washer and a nut. Always in this order!
 - Never place washers between the lugs and the strips because this can result in excessive heat!
 - Only use nuts and washers supplied with the unit.
- The DC power terminals are floating in relation to Protective Earth.
- After installation mount the safety cover over the DC power terminals.

LAN-CONNECTOR

- Insert a standard RJ45 network cable to the LAN-connector at the rear side, see fig. 3 - 1 and make connection to a Local Area Network (LAN) to perform a firmware update and use the units' web browser, see chapter 2.
- The LAN-connector is at Protective Earth level.

LOAD SENSING, INTERLOCK, USB, INTERFACES, SERIES-PARALLEL, MASTER/SLAVE

- Refer to user manual for connecting and using these features and options.

2 Operating the unit

FIRMWARE UPDATE

- Switch the unit on by rotating the mains switch on the front panel clockwise.
- In the unit menu, check the firmware revision via Menu > System > info > Unit > Version.
- On a computer, check at www.DeltaPowerSupplies.com if there is new firmware available via: *Products > SM15K > Downloads*.
- If newer, download the firmware package to the computer and connect this to the same LAN as the unit.
- In the unit menu, check the IP-address via Menu > Interfaces > LAN > Address*.
- On the computer, open the SM15K web interface using an internet browser by entering the IP-address of the unit in the address bar of the browser.
- In the web interface, go to *Administration > Firmware*.
- Select "Choose File" and browse to the downloaded package, enter password and "Start Update".

***Note:** when DHCP is enabled, the IP-address can change, for example after a power cycle.

FIRST OPERATION

- The first line in the front display indicates the **actual output voltage and current**. The second line shows the settings of the controls.
- Check the text 'front' is indicated - this means the unit is in **local-operation** and can be controlled by the V-knob and A-knob at the front panel.
- **Switch the output on** by pressing the on/OFF button.
- **Turn the V- and A-knob** a half turn clockwise. Depending on the load, a voltage should now be present on the output and a current will run through the load.
- Depending on the load and settings, the unit will be either in **constant voltage, current or power mode**, respectively CV-, CC- or CP-mode.
- Respectively the indication 'CV' will appear on the first line, next to the actual voltage value. The indication 'CC' will appear next to the actual current value or 'CP' will appear next to the actual power value.

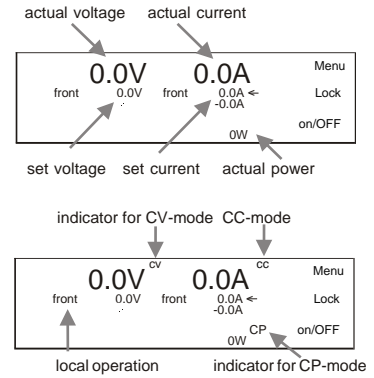

fig. 3 - 2, Start-up settings.

SOURCE & SINK CURRENT

- By default the A-knob at the front **sets the source current** 'CC+'.
- By pressing the buttons 'Lock' and 'Menu' simultaneously, the function of the A-knob changes from 'CC+' to 'CC-', to **set the sink current**. In the display the arrow behind the value for the current changes position, see fig 3 - 3.

SOURCE & SINK POWER

- Set the maximum power via Menu > Configuration > Prg Setting > Psettings.
- Here rotate the V-knob to **set the source power** from 0...15kW. This is the power the unit can deliver to the DC power terminals.
- Rotate the A-knob to **set the sink power** from 0...-15kW. This is the power the unit can absorb from the DC power terminals and feed back into the grid.

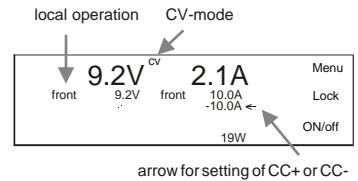

fig. 3 - 3, 19W output power.

LIMITATION OF SETTINGS

- By default, the settings for CV, CC and CP Limit are set to the maximum.
- **Change the limit settings** via Menu > Protection > Limits.

REMOTE PROGRAMMING

- By default a unit is in **local operation**, see fig. 3 - 3.
- In **remote operation** different programming options are available such as 'eth', 'web', 'seq', 'slot1', etc.
- Via the front menu the source can be set to the **required programming input** via: Menu > Configuration > Source.
- When connected to LAN, enter the unit's IP-address in a web browser to open the **web interface**. With this interface all above described parameters plus additional parameters can be set and read.
- For more information, see the chapter Remote Programming of the user manual.



fig. 3 - 4 The front console of the web interface for setting of the output and monitoring various parameters.

3 Download User Manual

FULL VERSION

- Check at www.DeltaPowerSupplies.com for the full version of the user manual via: *Products > SM15K > Downloads*.
- It is strongly recommended to regularly check for new versions of the user manual and firmware for additional functionality and improvements.

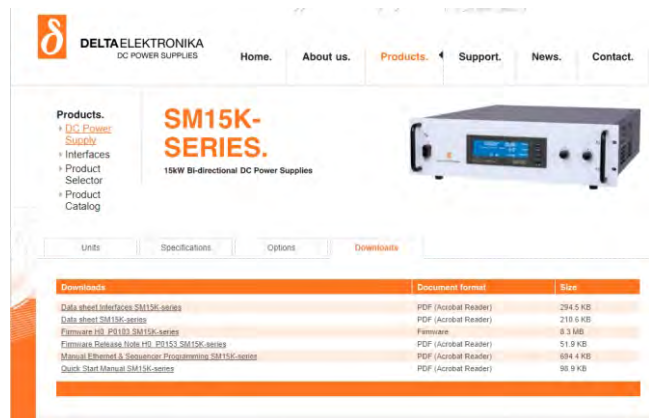

fig. 3 - 5 Regularly check for new versions of user manual and firmware.



DELTA ELEKTRONIKA B.V.
DC POWER SUPPLIES

Vissersdijk 4, 4301 ND
Zierikzee, the Netherlands

www.DeltaPowerSupplies.com
Tel. +31 111 413656

EC Declaration of Conformity - SM15K-series

We

Delta Elektronika
Vissersdijk 4
4301 ND ZIERIKZEE
The Netherlands

Declare under sole responsibility that the following Power Supplies:

SM500-CP-90
SM1500-CP-30

Meet the intent of Directives

2014/30/EC for Electromagnetic Compatibility
2014/35/EC regarding Electrical Safety. (Low Voltage Directive)
2011/65/EC Reduction of Hazardous Substances (RoHS2)

Compliance was demonstrated to the following specification as listed in the official Journal of the European Communities:

EN 61000-6-3 Generic Emissions: (residential, light industrial)

EN 55022 Radiated and conducted, Class **B**
EN 61000-3-12 Power Harmonics
EN 61000-3-11 Voltage fluctuation and flicker

EN 61000-6-1 Generic Immunity: (residential, light industrial)

EN 61000-6-2 Generic Immunity: (industrial environment)

EN 61000-4-2 Electrostatic Discharge
EN 61000-4-3 Radiated electromagnetic fields
EN 61000-4-4 Electrical Fast Transients / Bursts
EN 61000-4-5 Surge on DC output
EN 61000-4-5 Surge on line input
EN 61000-4-5 Surge on Signal
EN 61000-4-6 RF common mode, conducted
EN 61000-4-8 Power-frequency magnetic field

EN 60950 Safety of IT equipment

EN 61010 Safety of electrical equipment for measurement, control and laboratory use

J. Koopman,
Managing director
Zierikzee, July 2018