

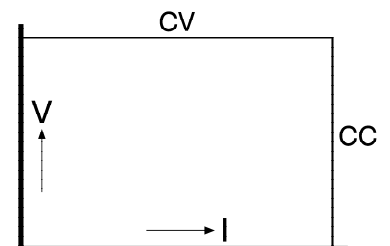

## ES 150 - Series 150W DC POWER SUPPLIES

Models	Voltage range	Current range
ES 015-10	0 - 15 V	0 - 10 A
ES 030-5	0 - 30 V	0 - 5 A
ES 075-2	0 - 75 V	0 - 2 A
ES 0300-0.45	0 - 300 V	0 - 0.45 A



### Features

- Very low output ripple and spikes
- EMC surpasses CE requirements:  
low emission & high immunity
- High programming speed
- Excellent dynamic response to load changes
- Protected against all overload and short circuit conditions
- Designed for a long life at full power

### Functionalities

- Voltage and current control with 10 turn potentiometers
- Master/Slave parallel and series operation with  
voltage and current sharing
- 19" rack mounting or for laboratory use  
(feet included)
- Optional Remote sensing
- Convection cooling

	ES 015-10	ES 030-5	ES 075-2	ES 0300-0.45
<b>Output</b> voltage current	0 - 15 V 0 - 10 A	0 - 30 V 0 - 5 A	0 - 75 V 0 - 2 A	0 - 300 V 0 - 450 mA
<b>Input</b> <b>AC</b> single phase, 48 - 62 Hz rated voltage range rated frequency  Input current @ 230 VAC power factor, 110 / 230 VAC full load  <b>DC</b>  internal fuses  standby input power (Vo=Io=0) standby input power (Vo=Vmax)	90 - 265 V 100 - 240 V 50 / 60 Hz  1 A 0.99 / 0.83  contact factory  4 AT  6 W 11 W			
<b>Efficiency</b> AC 230 V input, full load AC 110 V input, full load	83 % 80 %	84 % 82 %	84 % 81 %	84 % 81 %
<b>Regulation</b>				
Load 0 - 100% internal sensing optional external sensing	<b>CV</b> 15 mV 2 mV	6 mV 2 mV	5 mV 5 mV	10 mV 10 mV
Line 90 - 265 V AC	<b>CV</b> 0.2 mV	0.5 mV	1 mV	3 mV
<b>Load 0 - 100%</b> <b>Line 90 - 265 V AC</b> (internal voltage sensing)	<b>CC</b> 3 mA 0.5 mA	1 mA 0.2 mA	0.5 mA 0.1 mA	0.3 mA 0.05 mA
<b>Ripple + noise (full load)</b> rms (BW=300 kHz) p-p (BW=20 MHz)  rms (BW=300 kHz) p-p (BW=20 MHz)	<b>CV</b> 0.5 mV 8 mV  <b>CC</b> 1.5 mA 10 mA	0.6 mV 10 mV  0.5 mA 2 mA	1 mV 15 mV  0.1 mA 0.5 mA	7 mV 50 mV (typical 30 mV) 0.03 mA 0.2 mA
<b>Temp. coeff., per °C</b>	<b>CV</b> <b>CC</b>	5.10 <sup>-5</sup> 10.10 <sup>-5</sup>		
<b>Stability</b> after 1 hr warm-up during 8 hrs  t <sub>amb</sub> = 25 ± 1 °C, Vin = 230 VAC (internal voltage sensing for CC-stab.)	<b>CV</b> <b>CC</b> 10.10 <sup>-5</sup> 10.10 <sup>-5</sup>	10.10 <sup>-5</sup> 10.10 <sup>-5</sup>	10.10 <sup>-5</sup> 10.10 <sup>-5</sup>	10.10 <sup>-5</sup> 10.10 <sup>-5</sup>

<b>Analog Programming</b>	<b>CV</b>	<b>CC</b>
<b>Programming inputs</b> input range accuracy offset temp. coeff. offset input impedance	0 - 5 V ± 0.2% 0 ... + 3 mV (on 5 V) 10 µV / °C 1 MOhm	0 - 5 V ± 0.8% 0 ... + 10 mV (on 5 V) 60 µV / °C 1 MOhm
<b>Monitoring output</b> output range accuracy offset temp. coeff. offset output impedance	0 - 5 V ± 0.2% - 2 ... + 2 mV (on 5 V) 10 µV / °C 2 Ohm / max. 4 mA	0 - 5 V ± 0.8% - 10 ... 0 mV (on 5 V) 60 µV / °C 2 Ohm / max. 4 mA

<b>Reference voltage</b> on prog. connector	$V_{ref}$ TC	$5.137 \pm 10 \text{ mV}$ ( $R_o = 2 \text{ Ohm}$ , max. 4 mA) 50 ppm
<b>+12 V output</b> on prog. Connector	$V_o$ $R_o$	$12 \text{ V} \pm 0.5 \text{ V}$ 100 Ohm

<b>Status output</b> CC - status	CC - operation	5 V / 5 mA = logic 1
<b>Remote shutdown</b>	with + 5 V, 1 mA or relay contact	
<b>Indicators</b> (front panel)	CV-mode, CC-mode	
<b>Controls</b> (front panel)	Mains on/off, CV- and CC-potmeter	

<b>Programming speed</b> (resistive load)	<b>ES 015-10</b>	<b>ES 030-5</b>	<b>ES 075-2</b>	<b>ES 0300-0.45</b>
<b>Rise time (10 - 90%)</b> output voltage step	0 → 15 V	0 → 30 V	0 → 75 V	0 → 300 V
time, (100% load)	7 ms	15 ms	17 ms	10 ms
time, (10% load)	3 ms	6 ms	7 ms	4 ms
<b>Fall time (90 - 10%)</b> output voltage step	15 → 0 V	30 → 0 V	75 → 0 V	300 → 0 V
time, (100% load)	7 ms	15 ms	17 ms	10 ms
time, (10% load)	70 ms	150 ms	160 ms	100 ms

	<b>ES 015-10</b>	<b>ES 030-5</b>	<b>ES 075-2</b>	<b>ES 0300-0.45</b>
<b>Recovery time</b> recovery within di/dt of load step time, @ 50 - 100% load step max. deviation @ 230 VAC input voltage	50 mV 250 mA/μs 100 μs 160 mV	50 mV 125 mA/μs 100 μs 160 mV	50 mV 70 mA/μs 100 μs 150 mV	200 mV 6 mA/μs 130 μs 700 mV
<b>Output impedance</b> CV, 0-100 kHz	< 100 mOhm	< 200 mOhm	< 250 mOhm	< 5 Ohm
<b>Pulsating load</b> max. tolerable AC component of load current f > 1 kHz f < 1 kHz	2 A rms 10 A peak	2 A rms 5 A peak	2 A rms 2 A peak	2 A rms 0.45 A peak

<b>Insulation</b> input / output creepage / clearance	3750 Vrms (1 min.) 8 mm
input / case output / case	2500 Vrms 600 V DC
<b>Safety</b>	EN 60950 / EN 61010
<b>EMC</b> Power Supply Standard	<b>EN 61204-3</b> , Emission: residential, <b>light</b> industrial environment (CISPR22-Class B) Immunity: industrial environment
Generic Emission Generic Immunity	<b>EN 61000-6-3</b> , residential, <b>light</b> industrial environment (EN 55022 B) <b>EN 61000-6-2</b> , industrial environment
<b>Operating Temperature at full load</b>	- 20 to + 50 °C derate output to 75% at 60 °C
<b>Humidity</b>	max. 95% RH, non condensing, up to 40 °C max. 75% RH, non condensing, up to 50 °C
<b>Storage temperature</b>	- 40 to + 85 °C
<b>Thermal protection</b>	Output shuts down in case of insufficient cooling
<b>MTBF</b>	500 000 hrs

<b>Hold-Up time</b> (230 VAC input) Vout = 100% , Iout = 100% Vout = 85% , Iout = 100% Vout = 100% , Iout = 50%	25 ms 40 ms 60 ms
<b>Turn on delay</b> (230 VAC input) after mains switch on	250 ms
<b>Inrush current</b>	10 A with NTC resistor 30 Ohms cold resistance

	ES 015-10	ES 030-5	ES 075-2	ES 0300-0.45
<b>Series operation</b> max. total voltage Master / Slave operation	600 V with optional external Master / Slave Adapter			
<b>Parallel operation</b> max. total current Master / Slave operation	no limit max. 4 units			
<b>Remote sensing</b> (optional)	option P119	option P120	option P121	option P122
max. voltage drop per load lead	2 V <i>Note: voltage drop across load leads will subtract from max. available output voltage</i>			
<b>Over Voltage Limit</b> (fixed)	max. 18 V	max. 40 V	max. 90 V	max. 330 V
<b>Potentiometers</b> front panel control with knobs resolution screwdriver adjustment at front panel	standard 0.03%  option P001			
<b>Meters</b> scale voltage scale current accuracy V-meter accuracy A-meter	3.5 digit 0 - 15.00 V 0 - 10.00 A 0.5% + 2 digits 1% + 2 digits	3.5 digit 0 - 30.0 V 0 - 5.00 A 0.5% + 2 digits 1% + 2 digits	3.5 digit 0 - 75.0 V 0 - 2.00 A 0.5% + 2 digits 1% + 2 digits	3.5 digit 0 -300 V 0 - 450 mA 0.5% + 2 digits 1% + 2 digits

<b>Input Connector</b>	Euro-connector at rear panel 10 Amp / 65 °C IEC320/C14, EN60320/C14
<b>DC Output Terminals</b>	Standard:4 mm safety sockets at front-panel  Option: screw terminals (0.2-4 mm <sup>2</sup> ) at rear-panel (sockets at front removed) only combined with remote sensing, see remote sensing for option numbers (P119 - 122).
<b>Programming connector</b>	15 pole D-connector at rear panel (FEMALE)
<b>Cooling</b>	Convection cooling
<b>Enclosure</b> degree of protection	IP20
<b>Dimensions</b> (h x w x d)	52 x 222 x 202 mm
<b>Weight</b>	1.7 kg

CV = Constant Voltage  
CC = Constant Current

OVL = Over Voltage Limit

Specifications measured at  $t_{amb} = 25 \pm 5 \text{ }^\circ\text{C}$  and  $V_{in} = 230 \text{ VAC}$ , 50 Hz unless otherwise noted.

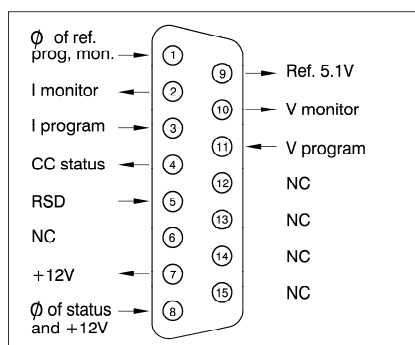

Connections programming connector

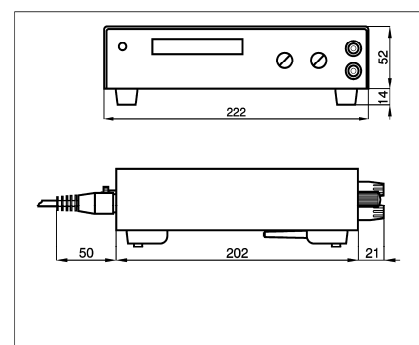

Dimensions

## Typical Applications

- Test and measurement
- Component device testing
- Controlled battery charging
- ATE in industrial production lines
- Electronic Circuit Development
- Laboratory analysis
- Medical research equipment
- Accurate current sources

## Available Options



### Increased Output Power

The conservatively rated unit allows to deliver extra output with the same reliability. At some

derating, either the maximum output voltage or the maximum output current can be increased by about 10%.

- Order Code - P069

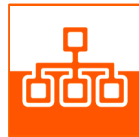

### Sequencer

Arbitrary Waveform generator or standalone automation. The sequencer is integrated in the Ethernet controller.

- Order Code - P150



### Secured Voltage and Current Setting

For a maximum security, the CV/CC settings can be adjusted with a screwdriver only and are protected

with a plastic cap from accidental adjusting.

- Order Code - P001

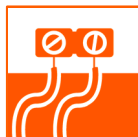

### Rear Power Output and Remote Sensing

Output terminals at the rear panel instead of bind posts at the front panel, includes remote sensing.

- Order Code ES015-10 - P119
- Order Code ES030-5 - P120
- Order Code ES075-2 - P121
- Order Code ES0300-0.45 - P122



### 19" Rack Mounting Adapter

Using the 19" mounting adapters, it is possible to position the ES units in a 19" rack. Several

configurations possible with multiple ES and / or PSC or ISO AMP modules.



### Software control and Interfaces

Interfaces to be installed by factory:

- RS232 controller - P148
- Ethernet (+ sequencer) - P150
- PROFIBUS controller - P279
- CANBUS controller - P280

External programming interface modules:

- IEEE488 controller module
- ISO AMP module

Notes: 1. Download the special datasheet about Battery Charging from <http://www.DeltaPowerSupplies.com/>.  
2. There is only room for one of the interfaces in a unit, see next page for configurations.

### 19" rack mounting



### Rear Connections

Linecord supplied      Input connector

**Standard unit:**  
Analog programming

Switches Manual / Programming  
Analog programming

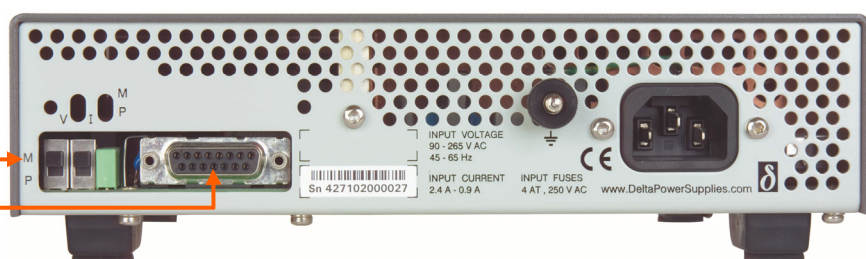

**Option P150:**  
Ethernet programming

Ethernet programming  
Switches Manual / Programming  
To combine with Option P119-122

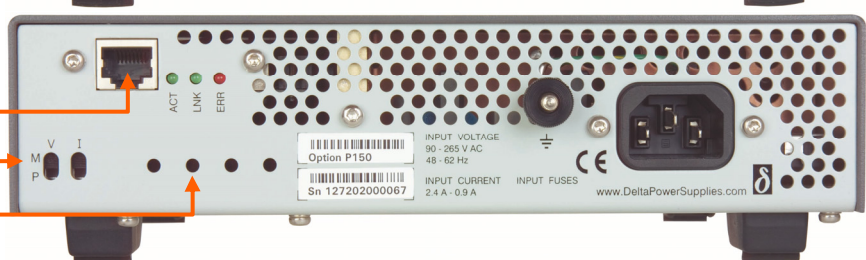

**Option P148:**  
RS232 programming

Switches Manual / Programming  
RS232 programming  
To combine with Option P119-122

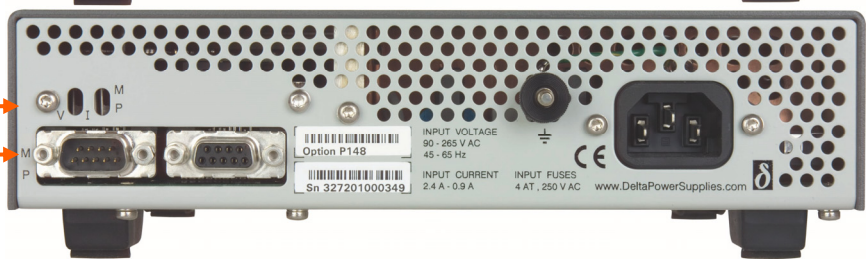

**Option P119 - 122:**  
Rear power outlet /  
Remote sensing

Rear power out / Remote sensing  
Switches Manual / Programming  
Analog programming

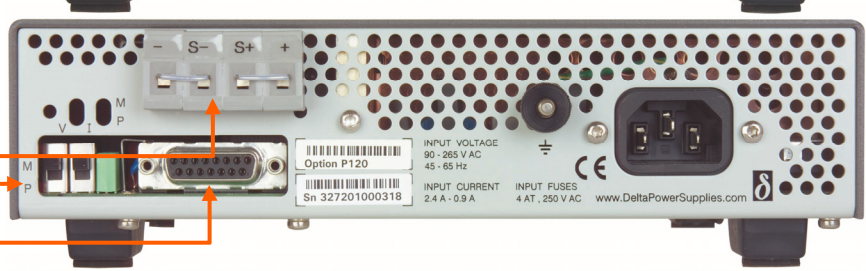

**Els Philips Service**  
Jilemnického 2; 911 01 Trenčín  
tel: +421 32 6582410  
fax: +421 32 6582592  
email: elso@elso.sk  
web: www.elso.sk